

# FT10MxNR

## 650 nm DC-10 MBd RedLink® Fiber Optic Transmitter

### Datasheet

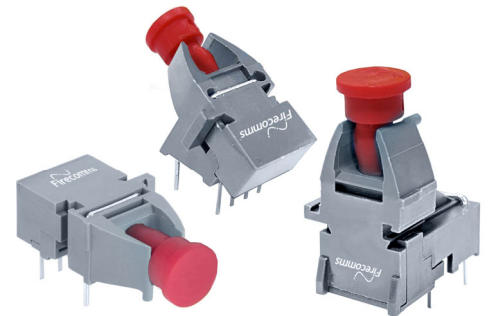

### DESCRIPTION

Firecomms DC to 10 MBd RedLink® transmitter is based on the highly reliable Firecomms designed Resonant Cavity Light Emitting Diode (RCLED) technology.

It is housed in a non-conducting plastic RedLink® connector. The 10 MBd transmitter is grey in colour. The housings are compatible with the Versatile Link style fiber plug and are optimised for use with Plastic Optic Fiber (POF) and Plastic Clad Silica (PCS).

The transmitter can be driven from TTL type logic drivers. It operates over the industrial temperature range of -40 °C to +85 °C, supporting many industrial applications where reliable command and control response is required in electrically harsh environments. The transmitter uses a large aperture (150 µm diameter) red (650 nm) eye-safe RCLED based on InGaP/InGaAlP/GaAs technology. It operates over a wide range of drive current that can be adjusted using a serial resistor to minimise current consumption for a given link distance.

### AVAILABLE OPTIONS

Table 1

#### ORDERING INFORMATION / PART NUMBERS

10 MBd Horizontal Package Non-Inverting, TTL	FT10MHNR
10 MBd Vertical Package Non-Inverting, TTL	FT10MVNR
10 MBd Tilted Package Non- Inverting, TTL	FT10MWNR

### FEATURES

- Ideal for use with POF
- Optimised for data rates from DC to 10 MBd
- Industrial temperature range -40 °C to +85 °C
- RoHS and UL compliant
- Flame retardant (UL 94 V-0) connector housings
- Horizontal, Vertical and 30° Tilted options
- RCLED transmitter with visible red light (650 nm wavelength)
- Low pulse width distortion
- The form factor of the RedLink® family is compatible with the Versatile Link range of connectors and cables

### APPLICATIONS

Table 2  
APPLICATIONS

Application	Automation and Industrial Control, Low-Speed Serial Communications, Voltage Isolation
Standard	Serial RS232, RS485, CAN Bus, Modbus, PROFIBUS, SERCOS
Distance	50 meters Step Index (SI) POF <sup>[1]</sup> 300 meters with 200 µm PCS fiber <sup>[1]</sup>
Speed	DC to 10 MBd

**Note:** 1. Depending on the installation conditions

## SPECIFICATIONS

**Table 3**  
**TRANSMITTER PIN DESCRIPTION**

Pin	Name	Symbol
1	RCLED ANODE	TD+
2	RCLED CATHODE	TD-
3	NOT CONNECTED	NC
4	NOT CONNECTED	NC
5	RETAINING PIN	GND
8	RETAINING PIN	GND

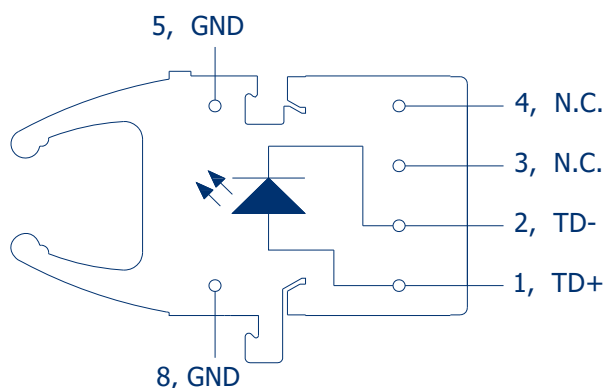
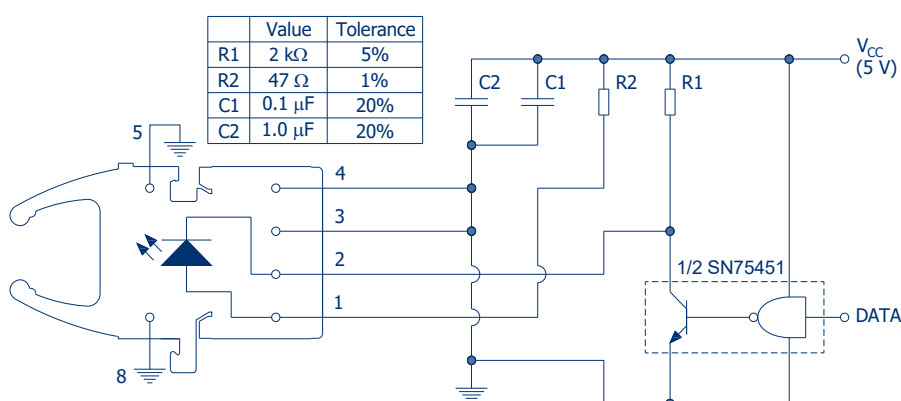

**FIGURE 1**  
**Transmitter pin-out, top view**

**Table 4**  
**REGULATORY COMPLIANCE**

Parameter	Symbol	Standard	Level
Electrostatic Discharge, Human Body Model (contact ESD)	HBM	Mil-STD-883	Level 2 (4 kV)
Radiated Emissions Immunity	$Vm^{-1}$	IEC 61000-4-3	15 $Vm^{-1}$
UL Certification	UL	60950-1	File No. E362227
Storage Compliance	MSL	J-STD-020	2a (4-week floor life)
Restriction of Hazardous Substances Directive	RoHS	Directive 2011/65/EU Incl. Amendment 2015/863	Certified compliant
Eye Safety		IEC 60825-1	LED Class 1

## RECOMMENDED APPLICATION CIRCUIT



**FIGURE 2**  
**Recommended transmitter application circuit. See note 7, Table 6**

**NOTE:**

*R2 = 47  $\Omega$ , therefore  $I_f$  drive current is approximately 60 mA. To reduce drive current, select a higher R2 value*

## SPECIFICATIONS

**Table 5**  
**ABSOLUTE MAXIMUM RATINGS**

*These are the absolute maximum ratings at or beyond which the part can be expected to be damaged*

**Notes:**

1. 260 °C for 10 seconds, one time only, at least 2.2 mm away from lead root
2. When peak forward current exceeds 60 mA then the duty cycle must maintain a pulse width (PW) less than 1  $\mu$ s and average forward current less than or equal to 60 mA. [60 mA  $\leq$  I<sub>FPK</sub>  $\leq$  90 mA  $\leftrightarrow$  I<sub>FAVG</sub>  $\leq$  60 mA AND PW  $\leq$  1  $\mu$ s]

Parameter	Symbol	Minimum	Maximum	Unit
Storage Temperature	T <sub>stg</sub>	-40	+85	°C
Operating Temperature	T <sub>op</sub>	-40	+85	°C
Soldering Temperature <sup>[1]</sup>	T <sub>slid</sub>		+260 <sup>[1]</sup>	°C
Tx Reverse Input Voltage	V <sub>BR</sub>		-10	V
Tx Forward Input Current <sup>[2]</sup>	I <sub>FDC</sub>		80	mA
Tx Peak Forward Input Current <sup>[2]</sup>	I <sub>FPK</sub>		1000	mA
Average Forward Input Current <sup>[2]</sup>	I <sub>FAVG</sub>		60	mA

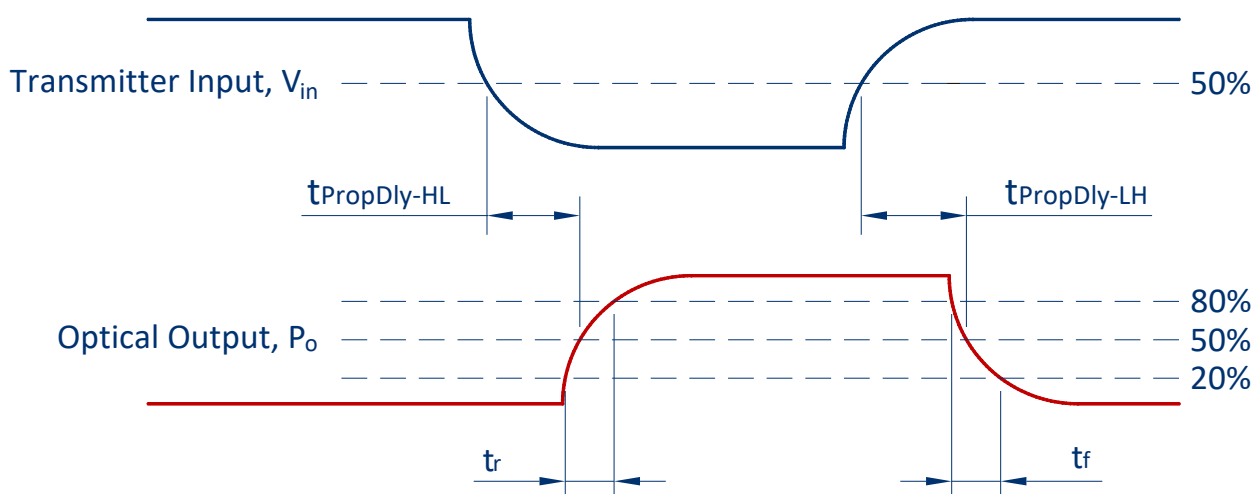

**FIGURE 3**  
Transmitter propagation delay and rise/fall time definitions as per application circuit of Figure 2

## SPECIFICATIONS

**Table 6**  
**TRANSMITTER ELECTRICAL AND OPTICAL CHARACTERISTICS**

Parameter	Symbol	Min	Typical	Max	Unit	Test Condition
<b>Test Conditions:</b>						
1. Test data was validated over the full temperature range of -40 °C to +85 °C, and over the full drive current range						
2. Optical power for POF is measured when coupled into 0.5 m of a 1 mm diameter 0.5 NA POF and a large area detector						
3. Optical power for PCS is measured when coupled into 0.5 m of a 200 μm diameter PCS and a large area detector						
4. As measured in the given application circuit (inverting) shown in Figure 2 over 50 cm of 0.5 NA POF						
5. Emission Wavelength (centroid) $\lambda_c = \sum i P_i \lambda_i / \sum i P_i$ . (Ref: EIA/TIA std. FOTP-127/6.1, 1991)						
6. Spectral Width Root Mean Squared (RMS) $\lambda_{RMS} = (\sum i P_i (\lambda_c - \lambda_i)^2 / \sum i P_i)^{1/2}$ (ref: EIA/TIA std. FOTP-127/6.3, 1991)						
7. Pins 5 and 8 are only used for mounting and retention purposes. Connect to ground						
Output Optical Power	$P_o$	-7.2	-3.5	+1.3	dBm	1 mm POF $I_{FDC} = 60$ mA
		-16.8	-9.0	-0.7	dBm	1 mm POF $I_{FDC} = 20$ mA
		-17.3	-12.5	-7.2	dBm	200 μm PCS $I_{FDC} = 60$ mA
Emission Wavelength (centroid) <sup>[4]</sup>	$\lambda_c$	635	650	665	nm	$I_{FDC} = 30$ mA
Spectral Width (RMS) <sup>[6]</sup>	$\lambda_{RMS}$		11	16	nm	$I_{FDC} = 30$ mA
Forward Voltage	$V_F$	1.8	2.1	2.65	V	$I_{FDC} = 60$ mA
Forward Voltage Temperature Coefficient	$\Delta V_F / \Delta T$		-3.3		mV/°C	$I_{FDC} = 60$ mA
Reverse Input Breakdown Voltage	$V_{BR}$	10			V	$I_{FDC} = -1$ μA
Diode Capacitance	$C_o$		11		pF	V = 0 V
Tx Numerical Aperture	NA		0.5			$I_{FDC} = 60$ mA
Data Rate		DC		10	MBd	Min UI = 100 ns Max f = 5 MHz
Optical Rise Time (20 % - 80 %)	$t_r$		6	9	ns	$I_{FAVG} = 30$ mA <sup>[4]</sup> Fig 3
Optical Fall Time (80 % - 20 %)	$t_f$		8	11	ns	$I_{FAVG} = 30$ mA <sup>[4]</sup> Fig 3
Propagation Delay Low-to-High (ELEC – OPTO)	$t_{PropDly\_LH}$	20	23	30	ns	$I_{FAVG} = 30$ mA <sup>[4]</sup> Fig 3
Propagation Delay High-to-Low (ELEC – OPTO)	$t_{PropDly\_HL}$	18	25	36	ns	$I_{FAVG} = 30$ mA <sup>[4]</sup> Fig 3
Pulse Width Distortion	PWD	-4	2	8	ns	$I_{FAVG} = 30$ mA <sup>[4]</sup> Fig 3

## SPECIFICATIONS

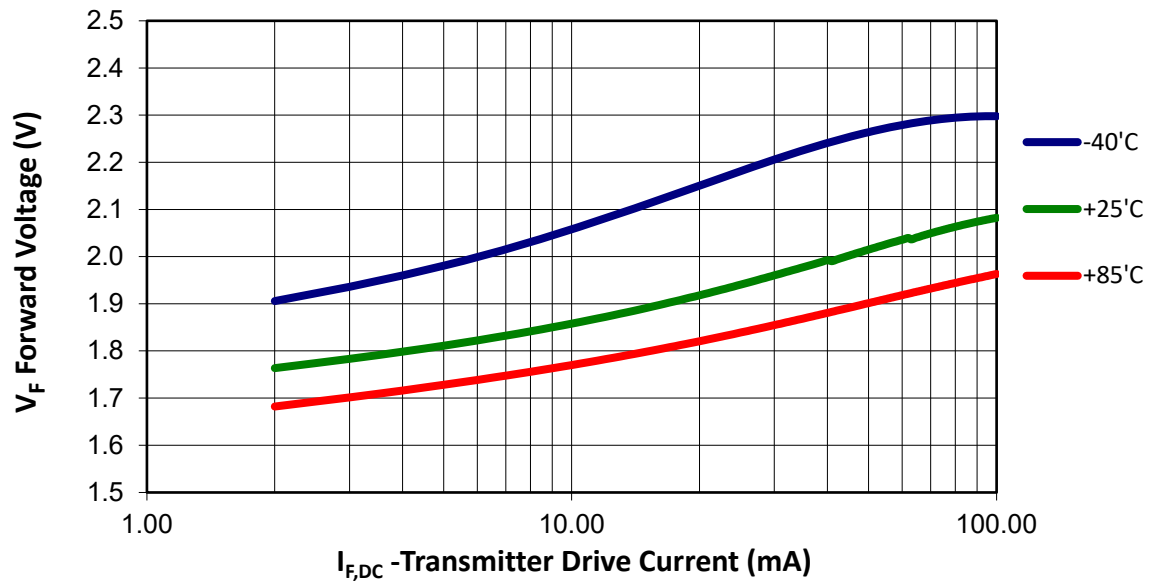

FIGURE 4  
Typical forward voltage ( $V_F$ ) vs. drive current ( $I_{F,DC}$ )

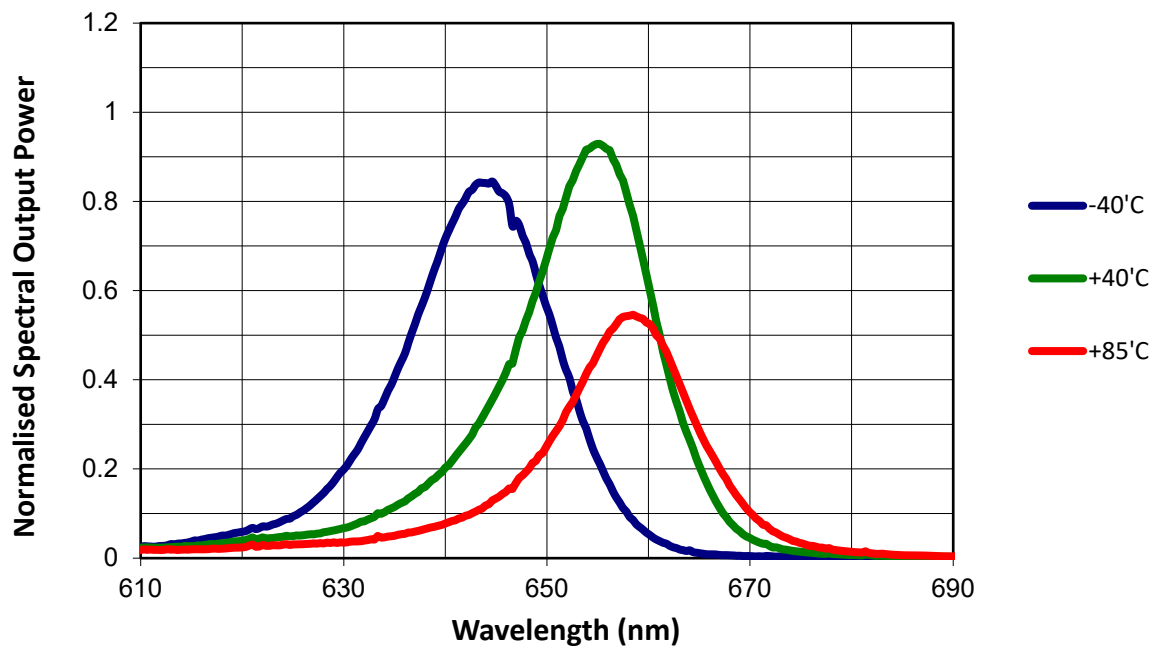
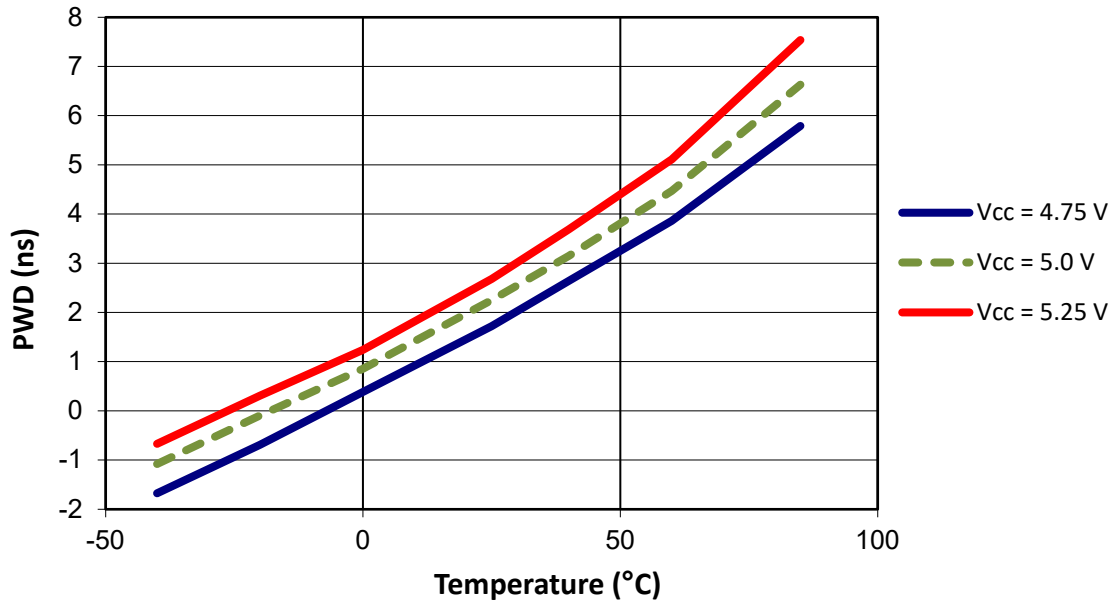
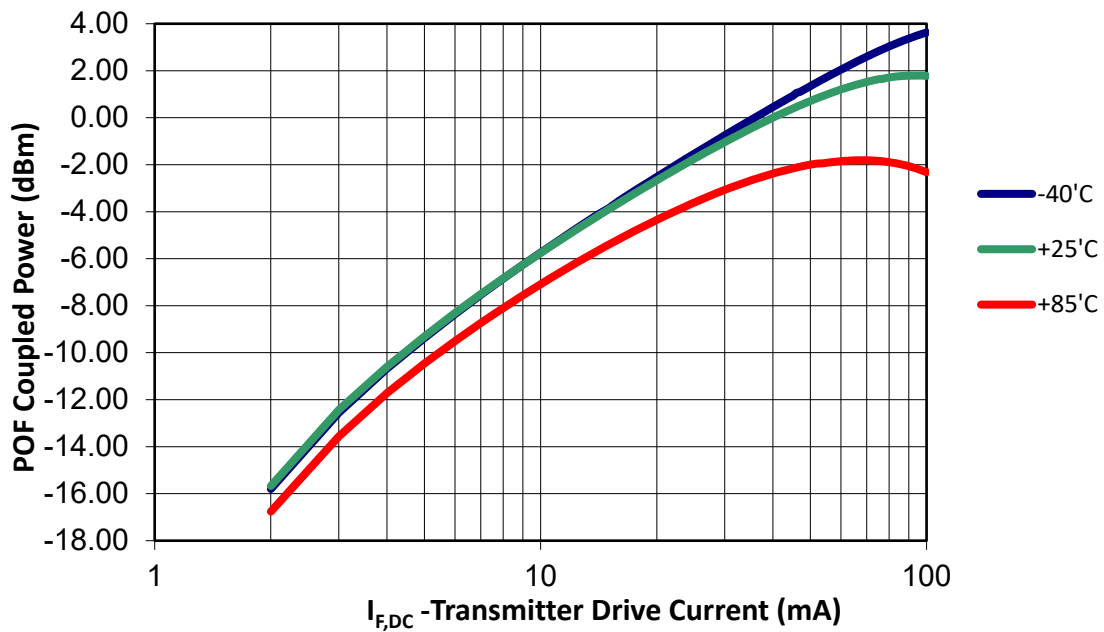

FIGURE 5  
Typical normalized optical spectra

**SPECIFICATIONS**

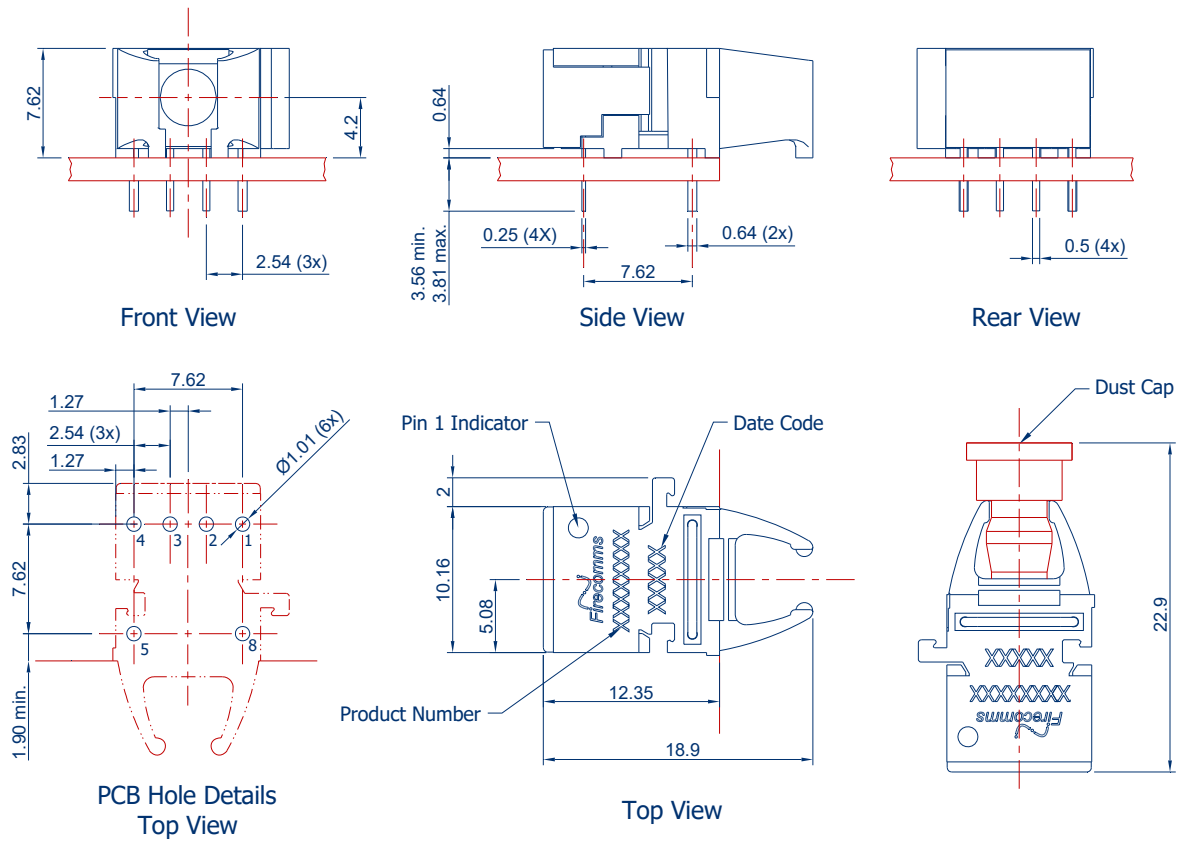

**FIGURE 6**  
Typical optical pulse width distortion vs. temperature and power supply voltage (in recommended drive circuit)

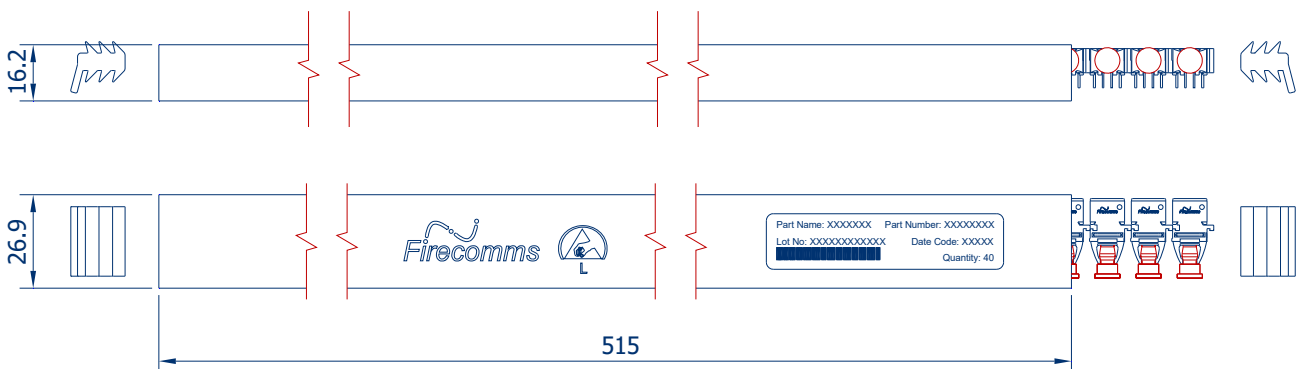

**FIGURE 7**  
Typical POF coupled optical power vs. drive current

**MECHANICAL DATA, HORIZONTAL**

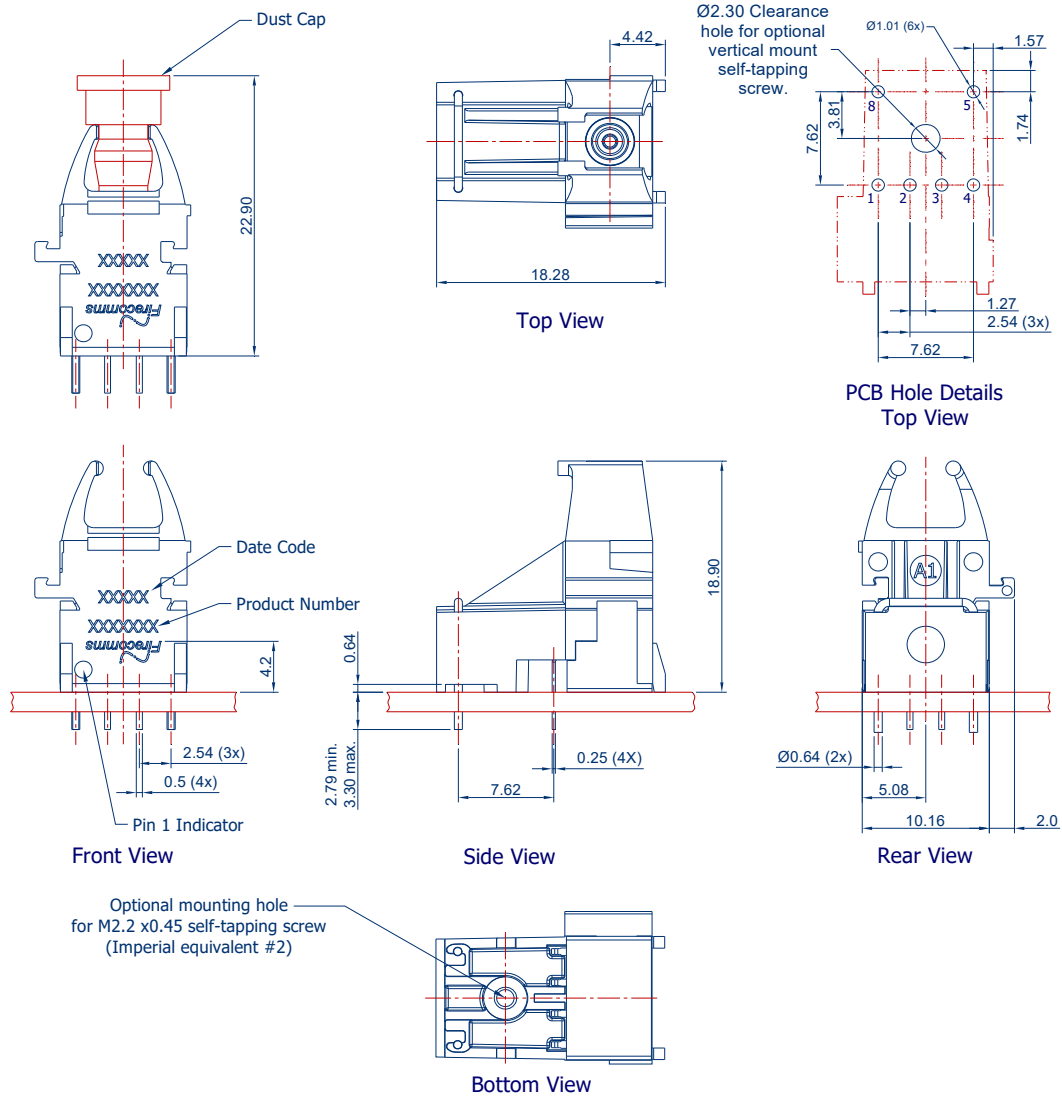

**FIGURE 8**  
Mechanical dimensions of RedLink® horizontal connectors and PCB footprint, which is a top view  
General dimensional tolerance is  $\pm 0.2$  mm

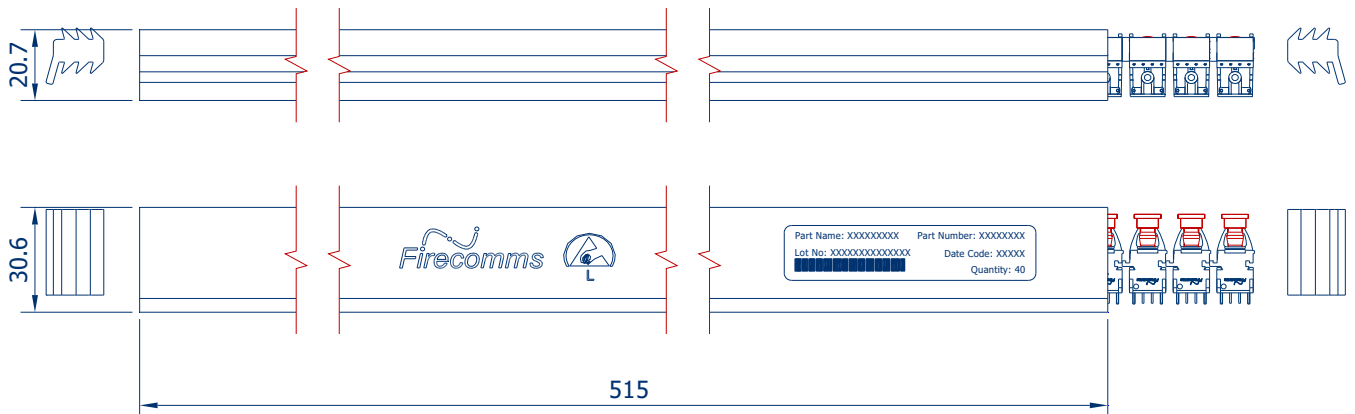

**FIGURE 9**  
Packing tube for Firecomms RedLink® horizontal connectors

### MECHANICAL DATA, VERTICAL

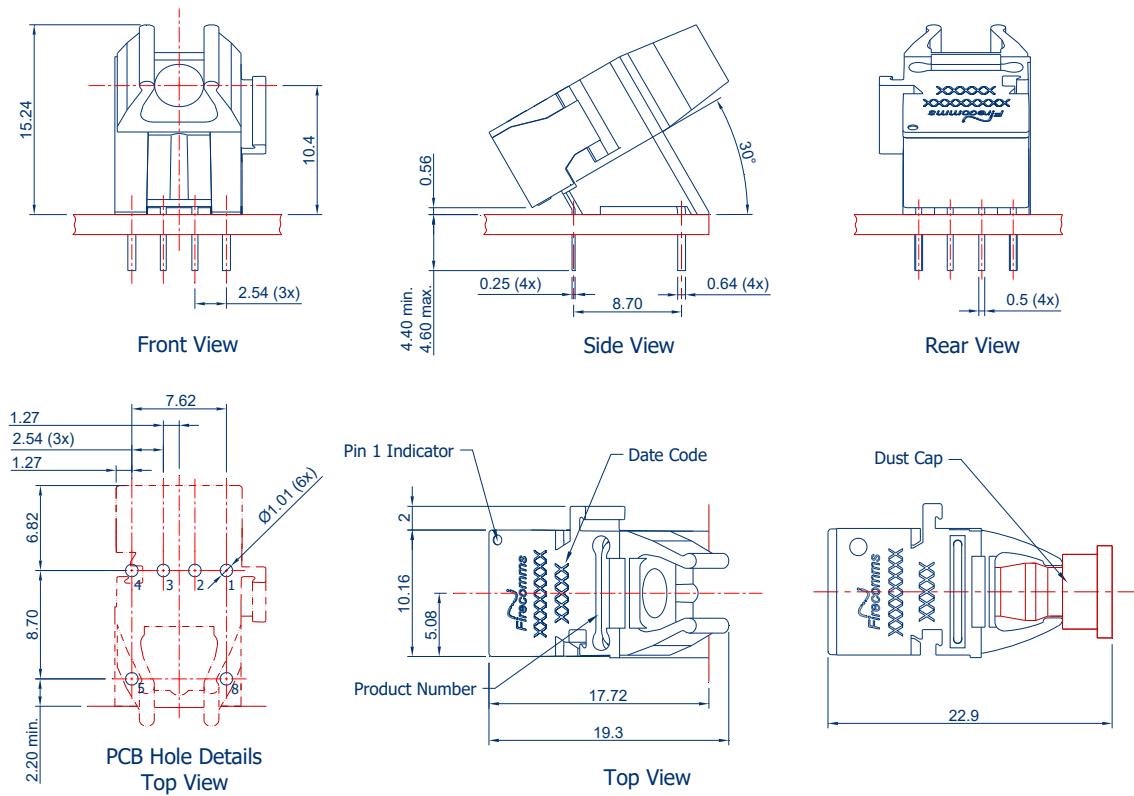

**FIGURE 10**  
 Mechanical dimensions of RedLink® vertical connectors and PCB footprint, which is a top view  
 General dimensional tolerance is  $\pm 0.2$  mm

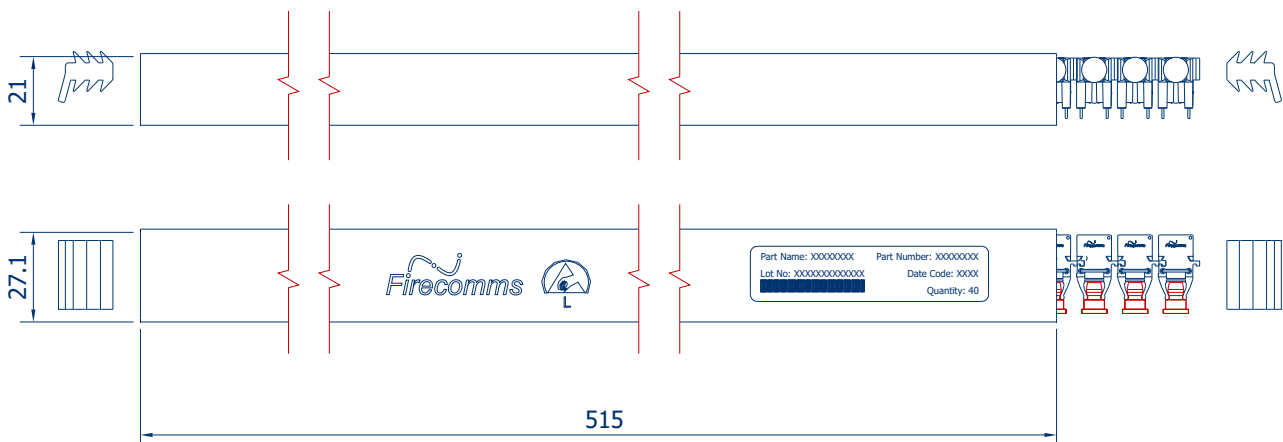

**FIGURE 11**  
 Packing tube for Firecomms RedLink® vertical connectors

## MECHANICAL DATA, 30° TILTED



**FIGURE 12**  
**Mechanical dimensions of RedLink® tilted connectors and PCB footprint, which is a top view**  
 General dimensional tolerance is  $\pm 0.2$  mm



**FIGURE 13**  
**Packing tube for Firecomms RedLink® tilted connectors**

## **PART HANDLING**

Firecomms RedLink® connectors are auto-insertable and tested for handling in static-controlled assembly processes (Human Body Model - HBM). Cleaning, degreasing and post solder washing should be carried out using standard solutions compatible with both plastics and the environment. For example, recommended solutions for degreasing are alcohols (methyl, isopropyl and isobutyl). Acetone, ethyl acetate, phenol or similar solution-based products are not permitted.

In the soldering process, non-halogenated water-soluble fluxes are recommended. RedLink® connectors are not suitable for use in reflow solder processes (infrared/vapor-phase reflow). The dust plug should remain in place during soldering, washing and drying processes to avoid contamination of the active optical area of each part.

The Moisture Sensitivity Level (MSL) classification of this device is 2a according to JEDEC J-STD-020.

The shelf life of an unopened MBB (Moisture Barrier Bag) is 24 months at < 40 °C and < 90 % R.H.

Once the Moisture Barrier Bag is opened, the devices can be either;

- a) Stored in normal factory conditions < 30 °C and < 60 % R.H. for a maximum of 672 hours (4 Weeks) prior to soldering
- b) Stored at < 10 % R.H. (Dry Cabinet)

## PACKING INFORMATION

Components are packed in PVC anti-static tubes and in moisture barrier bags. Bags should be opened only in static-controlled locations, and standard procedures should be followed for handling moisture sensitive components.

**Table 7**  
**PACKING INFORMATION**

	Horizontal	Vertical	Tilted
Components per Tube	40	40	40
Tube Length	515 mm	515 mm	515 mm
Tube Height	16.2 mm	20.7 mm	21 mm
Tube Depth	26.9 mm	30.6 mm	27.1 mm
Tubes per Bag	5	5	5
Bags per Inner Carton	1	1	1
Inner Carton Length	630 mm	630 mm	630 mm
Inner Carton Width	70 mm	70 mm	70 mm
Inner Carton Height	105 mm	105 mm	105 mm
Weight per Inner Carton, Complete	0.77 kg	0.92 kg	0.92 kg
Components per Inner Carton	200	200	200
Inner Cartons per Outer Carton	10	10	10
Outer Carton Length	650 mm	650 mm	650 mm
Outer Carton Width	235 mm	235 mm	235 mm
Outer Carton Height	376 mm	376 mm	376 mm
Weight per Outer Carton, Complete	8.13 kg	9.60 kg	9.60 kg
Components per Outer Carton	2,000	2,000	2,000

For the most recent revision or further information please visit [www.firecomms.com](http://www.firecomms.com) or contact the company directly at the following address, Firecomms Ltd, 2200 Airport Business Park, Cork, IRELAND. Copyright© 2004-2025 Firecomms. All rights reserved. Firecomms refers to Firecomms Limited and/or its subsidiaries. Firecomms assumes no responsibility for inaccuracies or omissions in the information contained in this document. Specifications are subject to change without notice. No patent rights are granted to any of the circuits described herein.