

FT10MxLR

650 nm DC-10 MBd RedLink® Fiber Optic Transmitter

Datasheet



DESCRIPTION

Firecomms DC to 10 MBd low current RedLink® transmitter is a highly reliable Resonant Cavity Light Emitting Diode (RCLED) which operates as a visible optical source generating red 650 nm light at data rates from burst mode DC to a maximum of 10 MBd of continuous digital data. The RCLED is encapsulated in a lensed clear molded plastic package for optimum coupling to Plastic Optic Fiber (POF). It operates over the industrial temperature range of -40 °C to +85 °C.

The transmitter is assembled in a grey non-conducting plastic housing requiring low operating current supporting horizontal, vertical and tilted housing options. The use of the eye-safe, visible light simplifies link set-up and testing.

FEATURES

- Visible RCLED at red wavelength (650 nm)
- Optimised for data rates from DC to 10 MBd with low current consumption
- Ideal for use with Step Index (SI) Plastic Optic Fiber (POF)
- Industrial temperature range -40 °C to +85 °C
- RoHS compliant
- Flame retardant (UL 94 V-0) connector housings
- Low pulse width distortion
- Horizontal, Vertical and 30° Tilted options
- The form factor of the RedLink® family is compatible with the Versatile Link range of connectors and cables

AVAILABLE OPTIONS

Table 1
ORDERING INFORMATION / PART NUMBERS

| | |
|---|----------|
| 10 MBd Horizontal Package Non-Inverting, TTL | FT10MHLR |
| 10 MBd Vertical Package Non-Inverting, TTL | FT10MVLR |
| 10 MBd Tilted Package Non- Inverting, TTL | FT10MWLR |

APPLICATIONS

Table 2
APPLICATIONS

| | |
|--------------------|---|
| Application | Automation and Industrial Control, Low-Speed Serial Communications, Voltage Isolation |
| Standard | Serial RS232, RS485, CAN Bus, Modbus, PROFIBUS, SERCOS |
| Distance | 50 meters Step Index (SI) POF ^[1] |
| Speed | DC to 10 MBd |

Note: 1. Depending on the installation conditions and assuming use of a Firecomms 10 MBd receiver.

SPECIFICATIONS

Table 3
TRANSMITTER PIN DESCRIPTION

| Pin | Name | Symbol |
|-----|---------------|----------|
| 1 | RCLED ANODE | TD + |
| 2 | RCLED CATHODE | TD - |
| 3 | NOT CONNECTED | NC / GND |
| 4 | NOT CONNECTED | NC / GND |
| 5 | RETAINING PIN | GND |
| 8 | RETAINING PIN | GND |

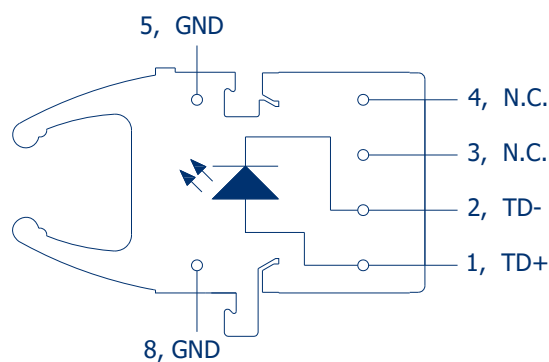

FIGURE 1
Transmitter pin-out, top view

Table 4
REGULATORY COMPLIANCE

| Parameter | Symbol | Standard | Level |
|--|-----------|--|------------------------|
| Electrostatic Discharge, Human Body Model (contact ESD) | HBM | Mil-STD-883 | Level 2 (4 kV) |
| Radiated Emissions Immunity | Vm^{-1} | IEC 61000-4-3 | 15 Vm^{-1} |
| UL Certification | UL | 60950-1 | File No. E362227 |
| Storage Compliance | MSL | J-STD-020 | 2a (4-week floor life) |
| Restriction of Hazardous Substances Directive | RoHS | Directive 2011/65/EU Incl. Amendment 2015/863 | Certified compliant |

RECOMMENDED APPLICATION CIRCUIT

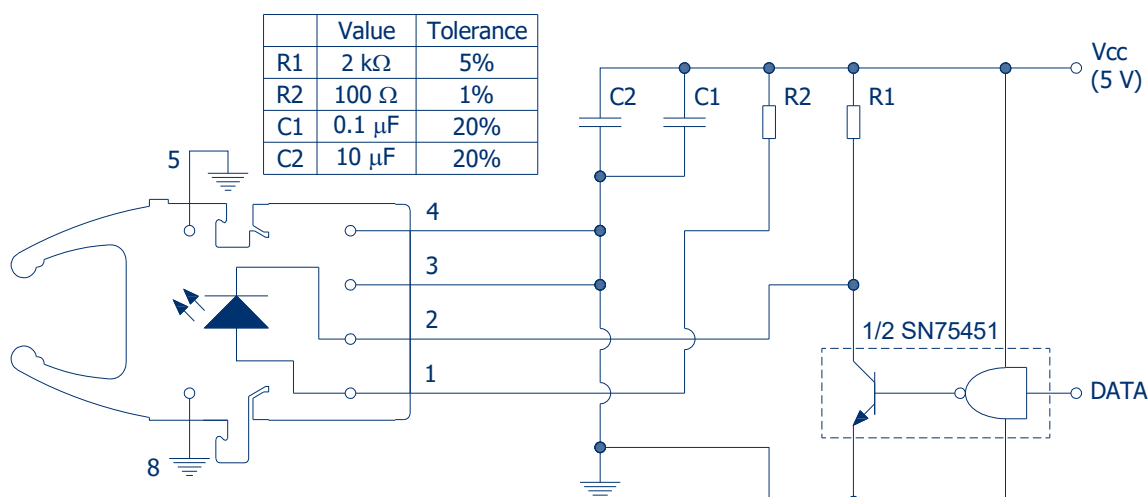

FIGURE 2
Recommended transmitter application circuit. See note 6, Table 6

SPECIFICATIONS

Table 5
ABSOLUTE MAXIMUM RATINGS

These are the absolute maximum ratings at or beyond which the part can be expected to be damaged

Notes:

1. 260 °C for 10 seconds, one time only, at least 2.2 mm away from lead root
2. When peak forward current exceeds 30 mA, the duty cycle must maintain a pulse width (PW) less than 1 μ s and average forward current less than or equal to 30 mA. [30 mA \leq I_{FPK} \leq 45 mA \leftrightarrow I_{FAVG} \leq 30 mA AND PW \leq 1 μ s]

| Parameter | Symbol | Minimum | Maximum | Unit |
|--|-------------------|---------|---------------------|------|
| Storage Temperature | T _{stg} | -40 | +85 | °C |
| Operating Temperature | T _{op} | -40 | +85 | °C |
| Soldering Temperature ^[1] | T _{slid} | | +260 ^[1] | °C |
| Tx Reverse Input Voltage | V _R | | 3 | V |
| Tx Peak Forward Input Current ^[2] | I _{FPK} | | 45 | mA |
| Average Forward Input Current ^[2] | I _{FAVG} | | 30 | mA |

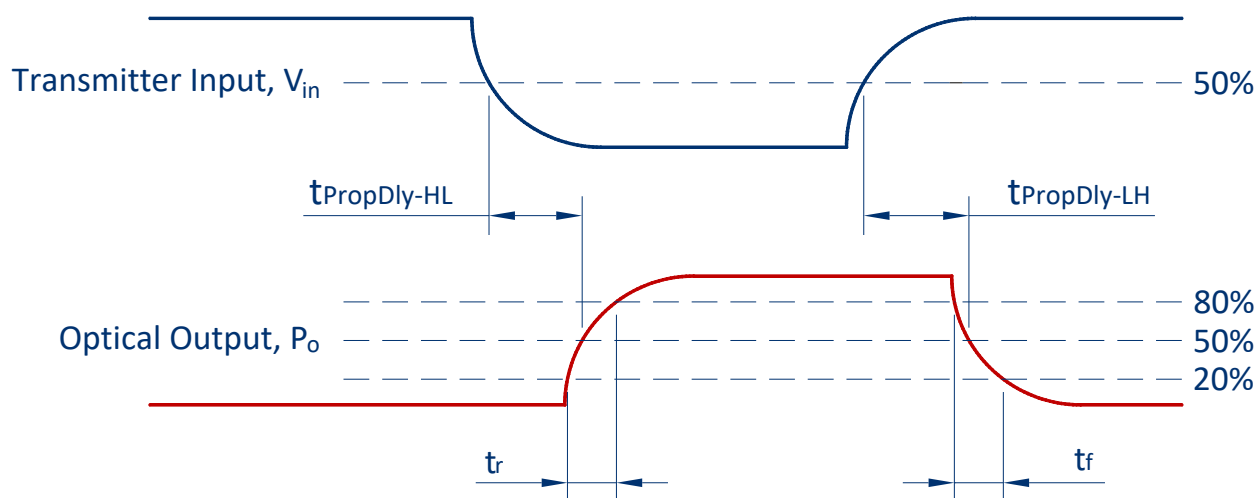

FIGURE 3
Transmitter propagation delay and rise/fall time definitions as per application circuit of Figure 2

SPECIFICATIONS

Table 6
TRANSMITTER ELECTRICAL AND OPTICAL CHARACTERISTICS

Test Conditions:

1. Test data was validated over the full temperature range of -40 °C to +85 °C, and over the full drive current range
2. Optical power for POF is measured when coupled into 0.5 m of a 1 mm diameter 0.5 NA POF and a large area detector
3. As measured in the given application circuit (inverting) as shown in Figure 2 with 50 cm of 0.5 NA POF
4. Emission Wavelength (centroid) $\lambda_c = \sum P_i \lambda_i / \sum P_i$. (Ref: EIA/TIA std. FOTP-127/6.1, 1991)
5. Spectral Width Root Mean Squared (RMS) $\lambda_{RMS} = (\sum P_i (\lambda_c - \lambda_i)^2 / \sum P_i)^{1/2}$. (Ref: EIA/TIA std. FOTP-127/6.3, 1991)
6. Pins 5 and 8 are only used for mounting and retention purposes only. Connect to ground.

| Parameter | Symbol | Min | Typical | Max | Unit | Test Condition |
|---|-----------------------------|-----|---------|-----|-------|--|
| Output Power | P | -3 | +2 | +4 | dBm | 1 mm POF I _{FDC} = 30 mA |
| | | -9 | -3 | -1 | dBm | 1 mm POF I _{FDC} = 10 mA |
| | | -11 | -5 | -3 | dBm | 1 mm POF I _{FDC} = 5 mA |
| | | -14 | -8 | -6 | dBm | 1 mm POF I _{FDC} = 3 mA |
| | | -20 | -15 | -12 | dBm | 200 μm PCS I _{FDC} = 30 mA |
| Emission Wavelength (centroid) ^[4] | λ_c | 640 | 660 | 680 | nm | I _{FDC} = 30 mA |
| Spectral Width (RMS) ^[5] | λ_{RMS} | | 11 | 20 | nm | I _{FDC} = 30 mA |
| Forward Voltage | V _F | 1.4 | 1.95 | 2.4 | V | I _{FDC} = 30 mA |
| Forward Voltage Temperature Coefficient | $\Delta V_F / \Delta T$ | | -3.5 | | mV/°C | I _{FDC} = 30 mA |
| Reverse Input Breakdown Voltage | V _{BR} | 20 | | | V | I _{FDC} = -1 μA |
| Diode Capacitance | C _o | | 11 | | pF | V = 0 V |
| Data Rate | | DC | | 10 | MBd | |
| Optical Rise Time (20 % - 80 %) | t _r | | 5 | 7 | ns | I _{FAVG} = 15 mA ^[3] |
| Optical Fall Time (80 % - 20 %) | t _f | | 7 | 9 | ns | I _{FAVG} = 15 mA ^[3] |
| Propagation Delay Low-to-High (Electrical-to-Optical) | PropDly_ LtoH (EL/OP) | 18 | 22 | 28 | ns | I _{FAVG} = 15 mA ^[3] |
| Propagation Delay High-to-Low (Electrical-to-Optical) | PropDly_ HtoL (EL/OP) | 16 | 24 | 36 | ns | I _{FAVG} = 15 mA ^[3] |
| Pulse Width Distortion | PWD | -2 | 2 | 8 | ns | I _{FAVG} = 15 mA ^[3] |

SPECIFICATIONS

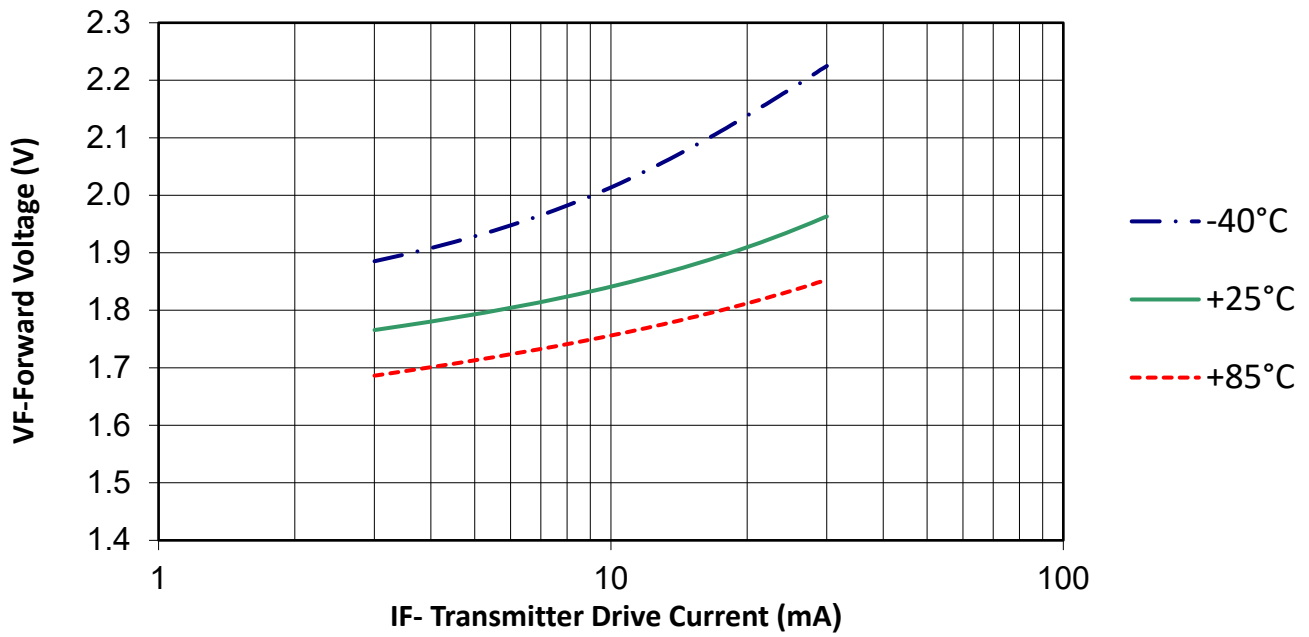

FIGURE 4
Typical forward voltage (VF) vs. drive current (IF, DC)

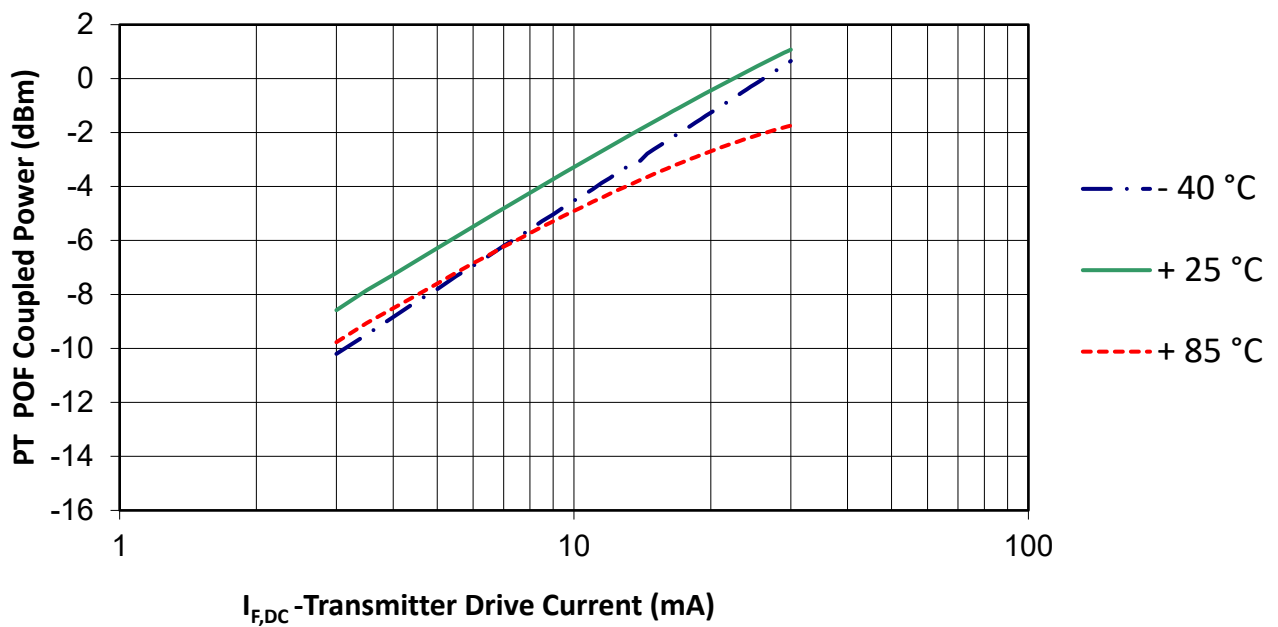

FIGURE 5
Typical normalized optical power vs. drive current

MECHANICAL DATA, HORIZONTAL

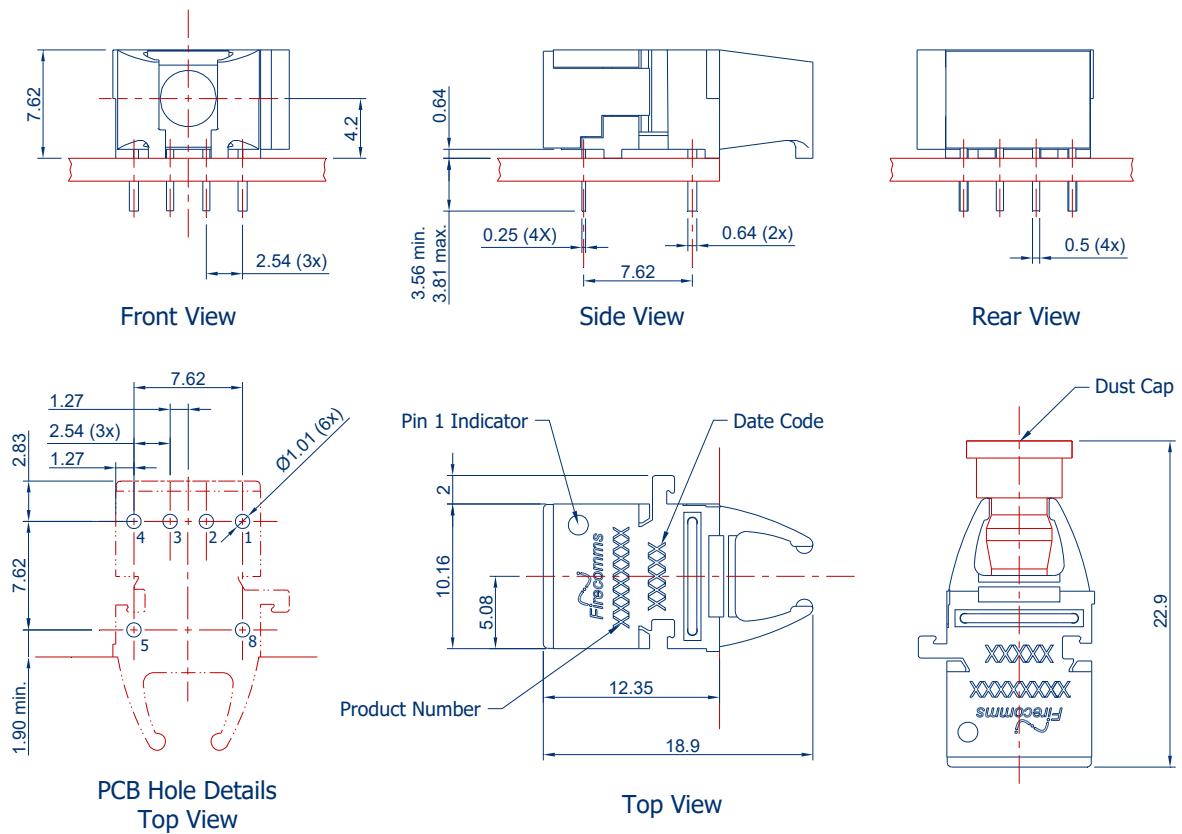

FIGURE 6
 Mechanical dimensions of RedLink® horizontal connectors and PCB footprint, which is a top view
 General dimensional tolerance is ± 0.2 mm

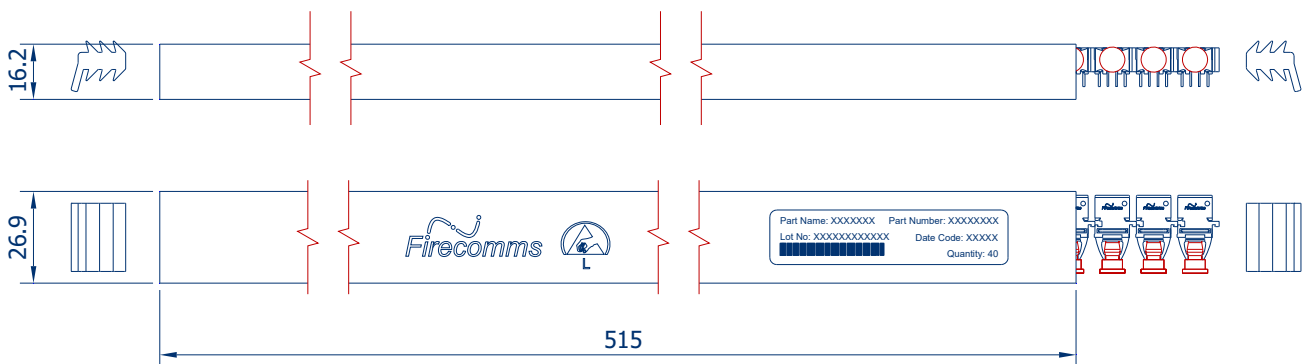

FIGURE 7
 Packing tube for Firecomms RedLink® horizontal connectors

MECHANICAL DATA, VERTICAL

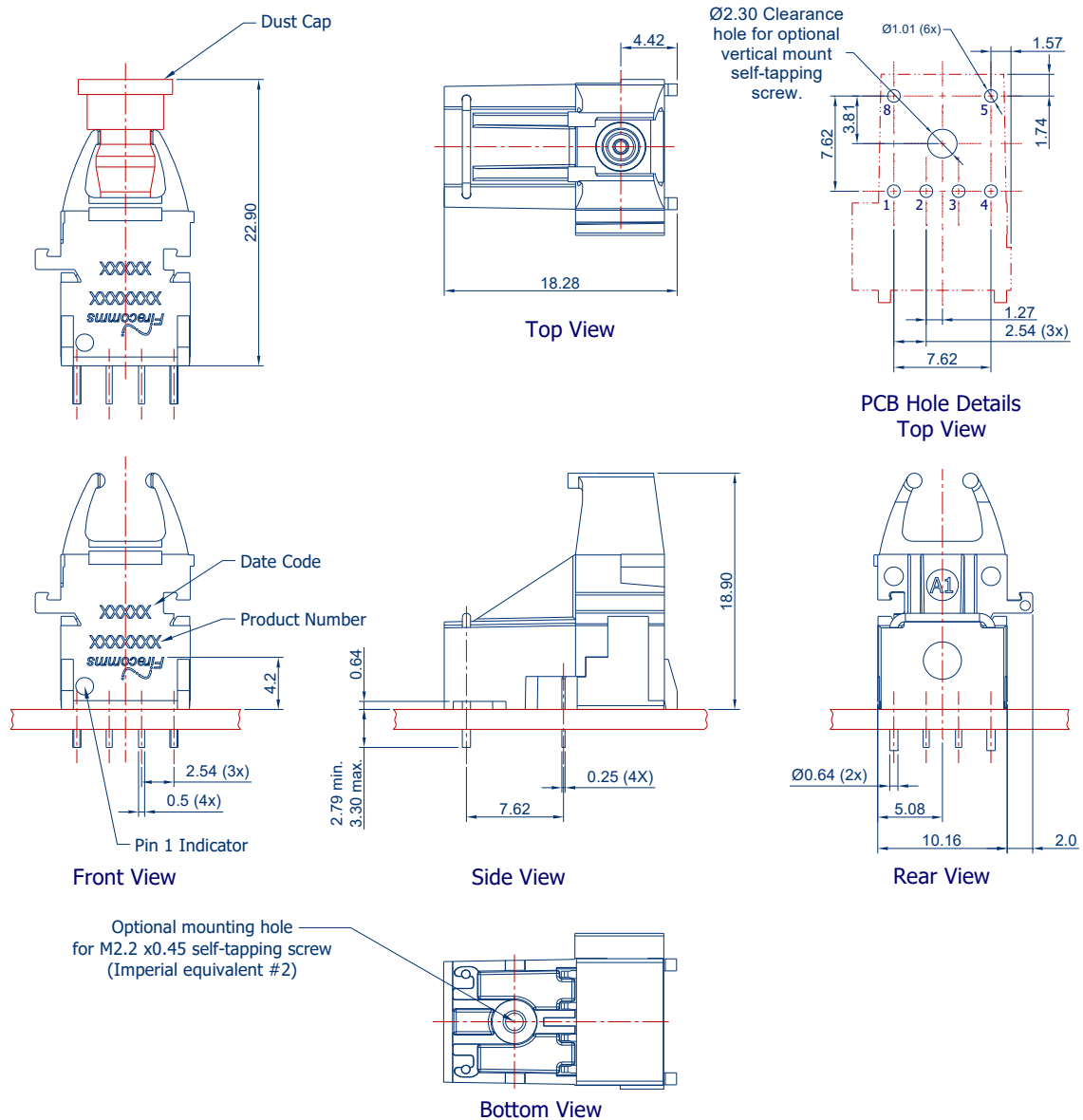

FIGURE 8
Mechanical dimensions of RedLink® vertical connectors and PCB footprint, which is a top view
General dimensional tolerance is ± 0.2 mm

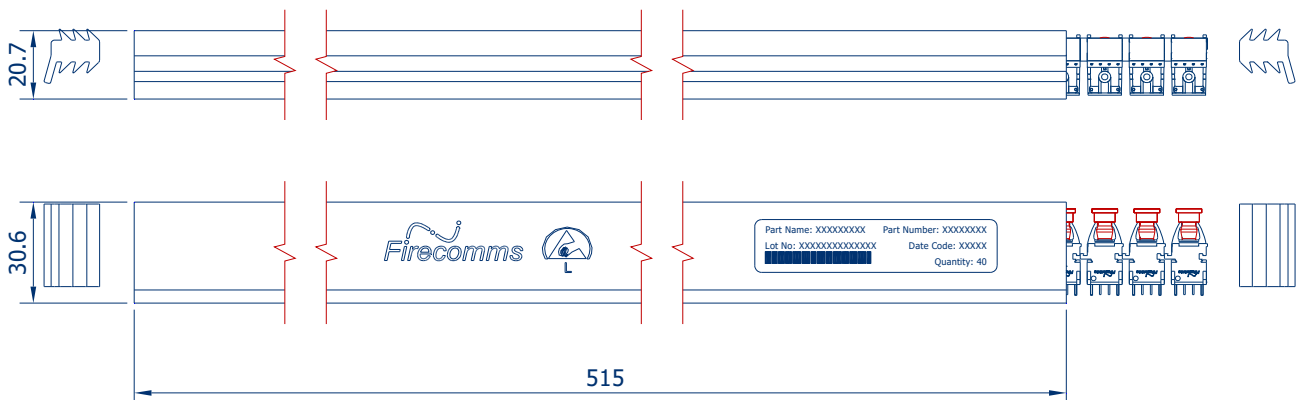

FIGURE 9
Packing tube for Firecomms RedLink® vertical connectors

MECHANICAL DATA, 30° TILTED

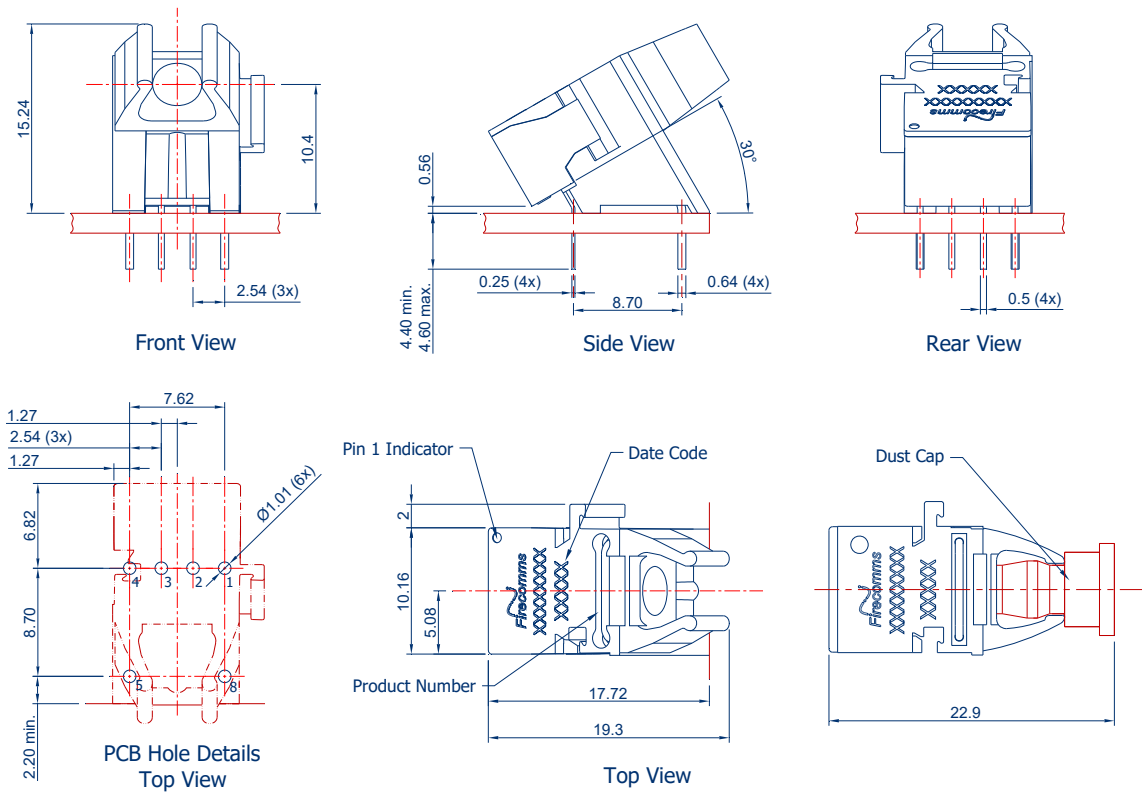

FIGURE 10
 Mechanical dimensions of RedLink® tilted connectors and PCB footprint, which is a top view
 General dimensional tolerance is ± 0.2 mm

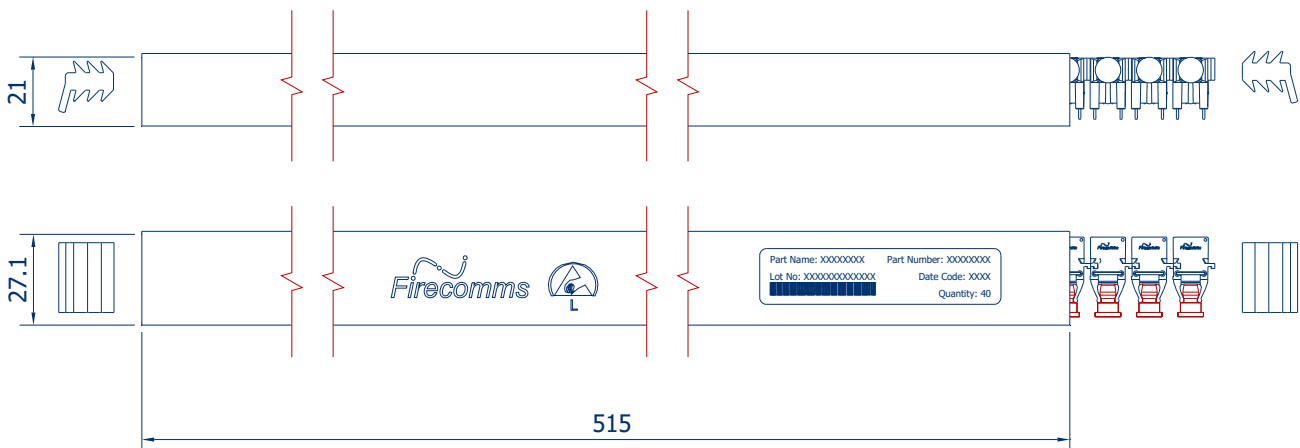

FIGURE 11
 Packing tube for Firecomms RedLink® tilted connectors

PART HANDLING

Firecomms RedLink® connectors are auto-insertable and tested for handling in static-controlled assembly processes (Human Body Model - HBM). Cleaning, degreasing and post solder washing should be carried out using standard solutions compatible with both plastics and the environment. For example, recommended solutions for degreasing are alcohols (methyl, isopropyl and isobutyl). Acetone, ethyl acetate, phenol or similar solution-based products are not permitted.

In the soldering process, non-halogenated water-soluble fluxes are recommended. RedLink® connectors are not suitable for use in reflow solder processes (infrared/vapor-phase reflow). The dust plug should remain in place during soldering, washing and drying processes to avoid contamination of the active optical area of each part.

The Moisture Sensitivity Level (MSL) classification of this device is 2a according to JEDEC J-STD-020.

The shelf life of an unopened MBB (Moisture Barrier Bag) is 24 months at < 40 °C and < 90 % R.H.

Once the Moisture Barrier Bag is opened, the devices can be either;

- a) Stored in normal factory conditions < 30 °C and < 60 % R.H. for a maximum of 672 hours (4 Weeks) prior to soldering
- b) Stored at < 10 % R.H. (Dry Cabinet)

PACKING INFORMATION

Components are packed in PVC anti-static tubes and in moisture barrier bags. Bags should be opened only in static-controlled locations, and standard procedures should be followed for handling moisture sensitive components.

Table 7
PACKING INFORMATION

| | Horizontal | Vertical | Tilted |
|-----------------------------------|-------------------|-----------------|---------------|
| Components per Tube | 40 | 40 | 40 |
| Tube Length | 515 mm | 515 mm | 515 mm |
| Tube Height | 16.2 mm | 20.7 mm | 21 mm |
| Tube Depth | 26.9 mm | 30.6 mm | 27.1 mm |
| Tubes per Bag | 5 | 5 | 5 |
| Bags per Inner Carton | 1 | 1 | 1 |
| Inner Carton Length | 630 mm | 630 mm | 630 mm |
| Inner Carton Width | 70 mm | 70 mm | 70 mm |
| Inner Carton Height | 105 mm | 105 mm | 105 mm |
| Weight per Inner Carton, Complete | 0.77 kg | 0.92 kg | 0.92 kg |
| Components per Inner Carton | 200 | 200 | 200 |
| Inner Cartons per Outer Carton | 10 | 10 | 10 |
| Outer Carton Length | 650 mm | 650 mm | 650 mm |
| Outer Carton Width | 235 mm | 235 mm | 235 mm |
| Outer Carton Height | 376 mm | 376 mm | 376 mm |
| Weight per Outer Carton, Complete | 8.13 kg | 9.60 kg | 9.60 kg |
| Components per Outer Carton | 2,000 | 2,000 | 2,000 |

For the most recent revision or further information please visit www.firecomms.com or contact the company directly at the following address, Firecomms Ltd, 2200 Airport Business Park, Cork, IRELAND. Copyright© 2004-2025 Firecomms. All rights reserved. Firecomms refers to Firecomms Limited and/or its subsidiaries. Firecomms assumes no responsibility for inaccuracies or omissions in the information contained in this document. Specifications are subject to change without notice. No patent rights are granted to any of the circuits described herein.