

FR50MHIR FR50MHNR FR50MVIR FR50MVNR

DC-50 RedLink® Fiber Optic Receiver

Datasheet



DESCRIPTION

The Firecomms DC-50 MBd RedLink receiver is a fully integrated photodiode and receiver IC. The receiver is housed in a miniature package to interface to plug-terminated lengths of Plastic Optic Fiber (POF) or 200 μm Plastic Clad Silica (PCS) fiber. When paired with the appropriate transmitter, the receiver is capable of delivering 50 Mbps digital signals over fiber and operate in the temperature range of $-40\text{ }^{\circ}\text{C}$ to $+85\text{ }^{\circ}\text{C}$. The device can operate from 5V or 3.3V DC power rails and can tolerate +/-10% supply variation.

The receiver is a robust optical to electrical receiver with integrated pulse width distortion minimization circuitry for reliable data transmission. The receiver features a push-pull TTL compatible CMOS output. It is available in inverting and non-inverting options.

AVAILABLE OPTIONS

Non-Inverting RedLink 50 MBd Receiver Horizontal	FR50MHNR
Inverting RedLink 50 MBd Receiver Horizontal	FR50MHIR
Non-Inverting RedLink 50 MBd Receiver Vertical	FR50MVNR
Inverting RedLink 50 MBd Receiver Vertical	FR50MVIR



FEATURES

- Ideal for use with POF or PCS fiber
- Optimized for data transmission from DC-50 MBd
- Industrial Temperature Range $-40\text{ }^{\circ}\text{C}$ to $+85\text{ }^{\circ}\text{C}$
- Dual 5 V and 3.3 V power supply with 10 % rail tolerance
- RoHS compliant and flame retardant (UL 94 V-0) housing
- Inverting and Non-Inverting options available
- Horizontal and Vertical options available
- Push Pull TTL Compatible CMOS output
- Ultra-low pulse width distortion to limit pulse distortion from burst mode data
- Compatible with Versatile Link cables and connectors

APPLICATIONS

Application	Automation and Industrial Control. Serial Communications. Voltage Isolation.
Standard	Serial RS232, RS485, CAN-Bus, MODBUS, Profibus
Distance	50 meters Step Index POF ^[1] 300 meters with 200 μm PCS fiber ^[1]
Speed	DC to 50 MBd

Note: 1. Depending on the installation conditions.

SPECIFICATIONS

Table 3
RECEIVER PIN DESCRIPTION

Pin	Name	Symbol
1	Receiver Output	V_O
2	Receiver Ground	Gnd
3	Receiver Vcc	Vcc
4	No Connect ^(a)	N.C.
5	Retaining Pin ^(b)	Gnd
8	Retaining Pin ^(b)	Gnd

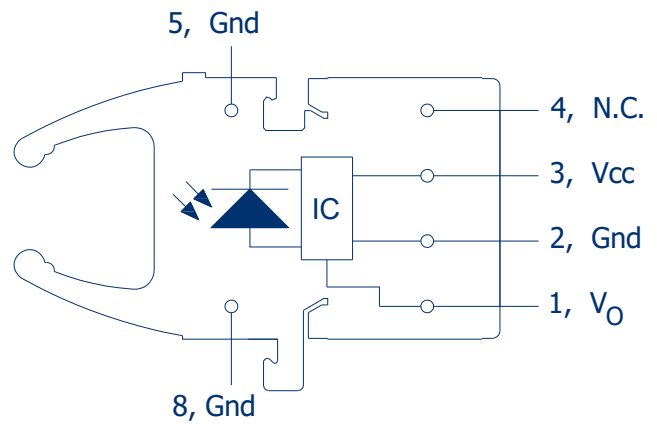

FIGURE 1
Receiver pin-out, top view

NOTE:

- Pin 4 is electrically isolated internally. Pin 4 may be externally connected to pin 1 for board layout compatibility with existing designs. Otherwise it is recommended pin 4 be grounded as in Figure 2
- Pins 5 and 8 are used for mounting and retaining purposes. Connect to ground.

Table 4
REGULATORY COMPLIANCE

Parameter	Symbol	Standard	Level
Electrostatic Discharge, Human Body Model (contact ESD)	HBM	Mil-STD-883	Level 2 (4 kV)
Radiated Emissions Immunity	Vm^{-1}	IEC 61000-4-3	15 Vm^{-1}
UL Certification	UL	94 V-0 Material	Files No. (Pending)
Restriction of Hazardous Substances Directive	RoHS	Directive 2011/65/EU	Certified compliant

RECOMMENDED APPLICATION CIRCUIT

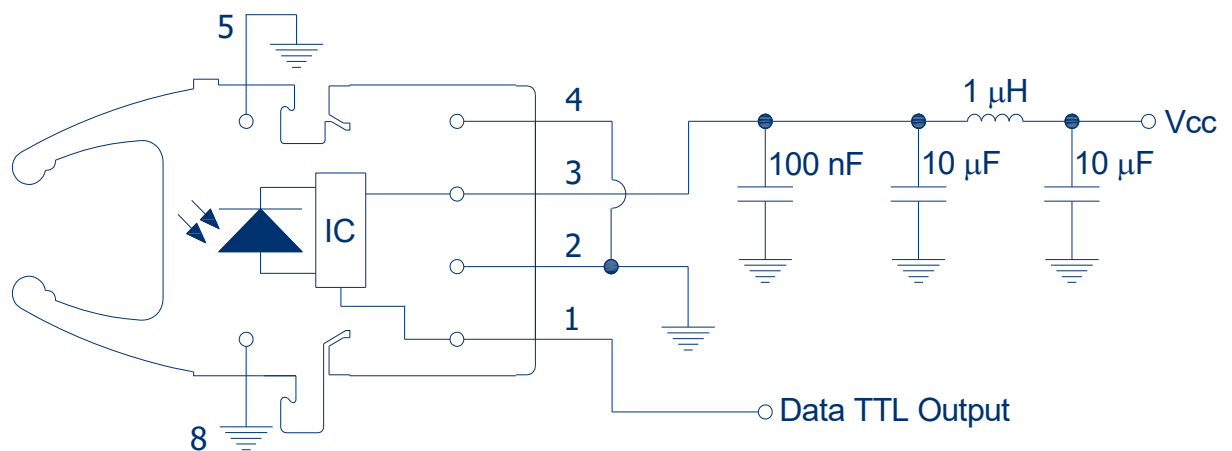

FIGURE 2
RedLink Receiver Application Circuit

SPECIFICATIONS

Table 5
ABSOLUTE MAXIMUM RATINGS

These are the absolute maximum ratings at or beyond which the FOT can be expected to be damaged

Notes:

1. 260°C for 10 seconds, one time only, at least 2.2 mm away from lead root

Parameter	Symbol	Minimum	Maximum	Unit
Storage Temperature	T_{stg}	-40	+85	°C
Operating Temperature	T_{op}	-40	+85	°C
Soldering Temperature ^[1]	T_{sld}		+260	°C
RX Supply Voltage	V_{cc}	-0.5	+5.5	V
RX Output Current	I_o	-16	+16	mA

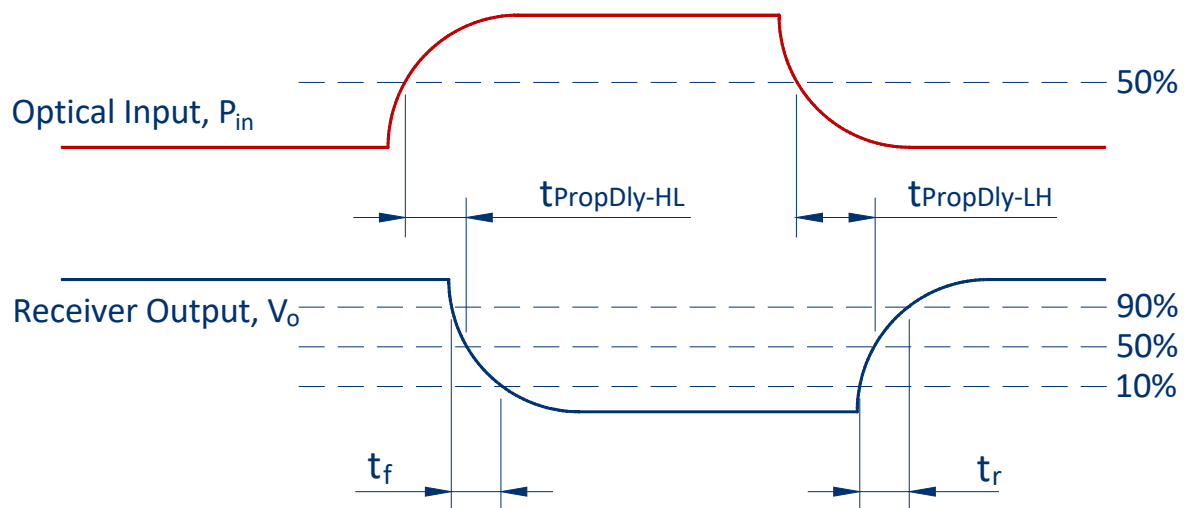

FIGURE 3 Receiver Propagation Delay and rise/fall time definitions for an inverting V_o output. Polarity of V_o is reversed for the non-inverting option.

SPECIFICATIONS

Table 6
RECEIVER ELECTRICAL AND OPTICAL CHARACTERISTICS

Test Conditions:

1. *Wake up Delay is the delay from VCC > 2.75 V to when the output will respond correctly to optical input. Output is held in tristate before this time*
2. *Test data was validated using a transmitter with a 5ns rise and fall time, over the full temperature range of -40 °C to +85 °C, over both supply rail voltage options of 5 V and 3.3 V ± 10%, and over the input optical received power as specified by P_H and P_L. Input power levels are for peak (not average) optical input levels. For 50% duty cycle data, peak optical power is twice the average optical power. Data referred to as typical are rated at +25 °C*
3. *Optical signal from the recommended Transmitter circuit.*
4. *Testing in the recommended receiver circuit (RL= 50 kΩ, CL(total)= 15 pF).*
5. *PWD for Optical Input of 50 MBd, NRZ 27-1 (PRBS7) data, resulting in a BER ≤ 10⁻⁹.*
6. *PWD for 1st to 3rd pulse is characterized with minimum Optical Input pulse width of 20 ns, with the 1st pulse being the worst case. For pulses > 20 ns the PWD will be less. If data rate < 1 MBd, then the pulse width distortion = PWD 1st to 3rd pulse.*

Parameter	Symbol	Min	Typical	Max	Unit	Test Condition
Supply Current	I _{CC}		20	24	mA	[2,3,4]
Wake Up Delay (power up)	t _{power-on}		40		µs	[1]
High Level Output Voltage	V _{OH}	V _{CC} – 0.05		V _{CC}	V	I _{OH-max} = 40 µA, [2]
Low Level Output Voltage	V _{OL}	0		0.05	V	I _{OL-max} =1.6 mA, [2]
Optical Power High (OPH)	P _H	-22		+2	dBm	[2,3]
Optical Power Low (OPL)	P _L			-40	dBm	[2,3]
Data Rate		DC		50	MBd	Min UI = 20 ns Max f = 25 MHz
Output Rise Time (10/90%)	t _r			5	ns	[2,3,4]
Output Fall Time (10/90%)	t _f			5	ns	[2,3,4]
Pulse Width Distortion for P _H range -20 to + 2 dBm	PWD	-4		+4	ns	[2,3,4,5]
Pulse Width Distortion for P _H range -20 to -22 dBm	PWD	-6		+6	ns	[2,3,4,5]
Pulse Width Distortion 1 st to 3 rd pulse	PWD _{init}	-7		+14	ns	[2,3,4,5,6]
Propagation Delay	t _{PropDly-HL}			45	ns	[2,3,4]
	t _{PropDly-LH}			45	ns	[2,3,4]

MECHANICAL DATA, HORIZONTAL

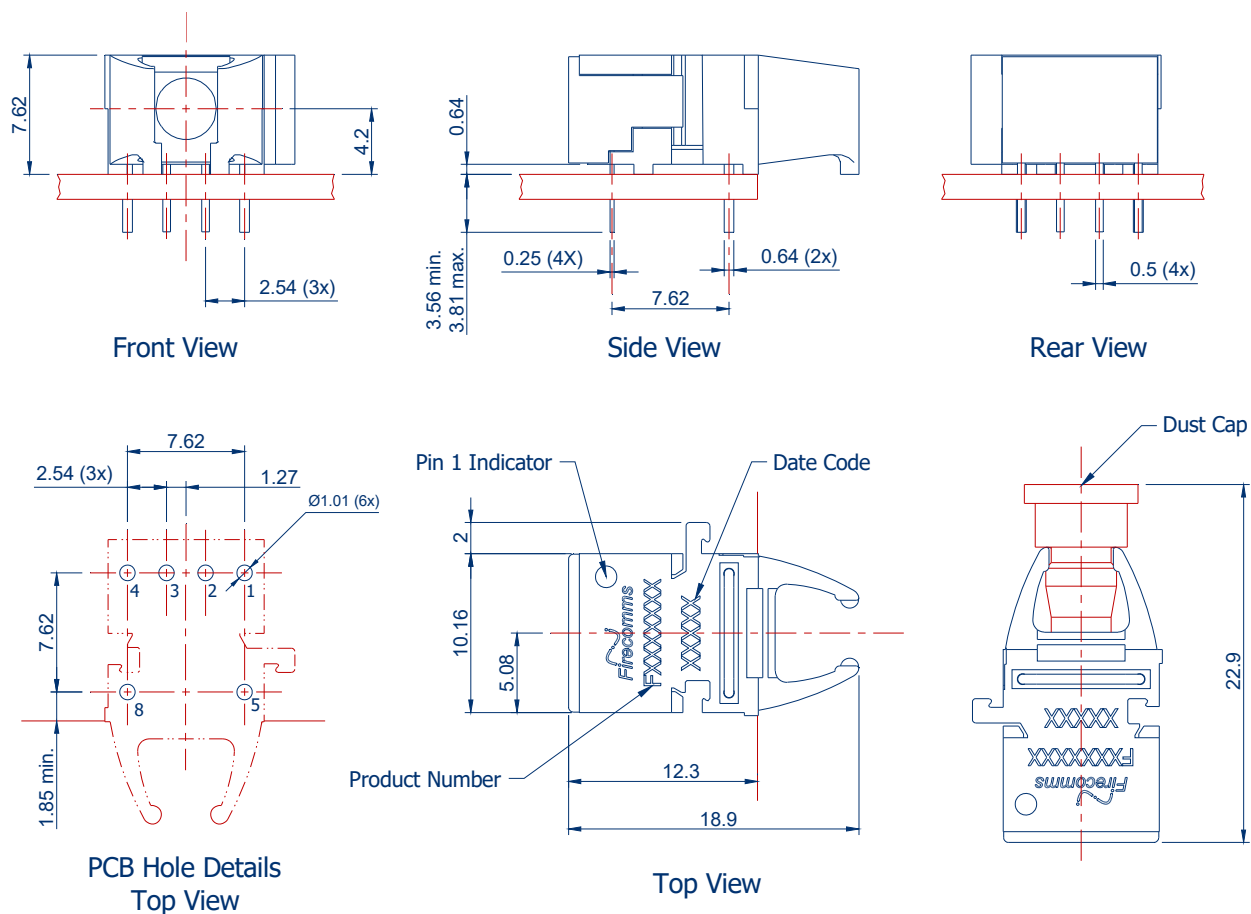

FIGURE 4
Mechanical dimensions of the horizontal receivers and PCB footprint, which is a top view
General dimensional tolerance is ± 0.2 mm

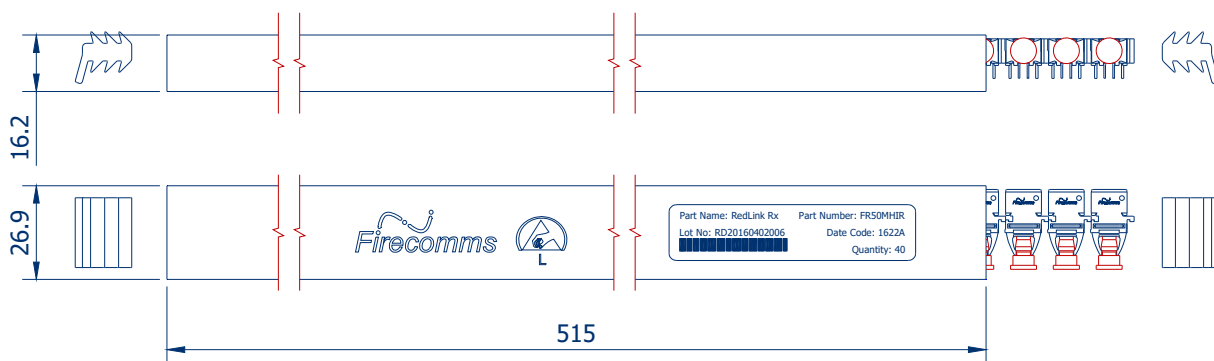

FIGURE 5
Packing tube for Firecomms Horizontal RedLink Receivers

MECHANICAL DATA, VERTICAL

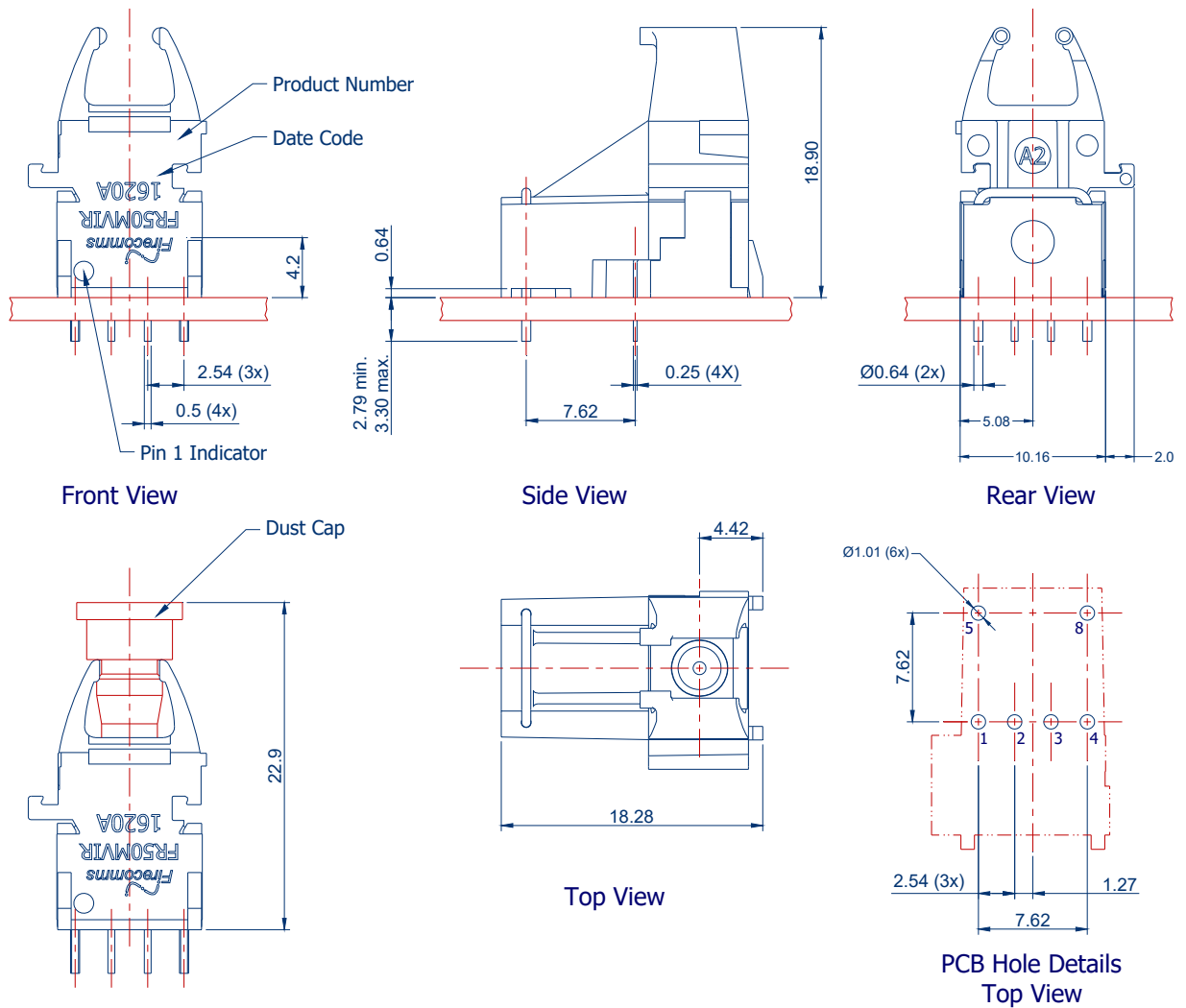

FIGURE 6
Mechanical dimensions of the vertical receivers and PCB footprint, which is a top view
General dimensional tolerance is ± 0.2 mm

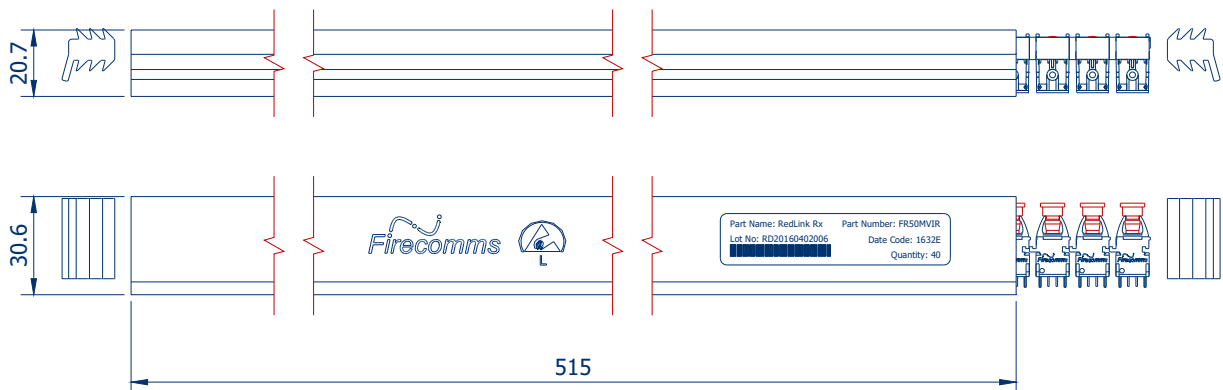

FIGURE 7
Packing tube for Firecomms Vertical RedLink Receivers

PART HANDLING

The Firecomms high voltage RedLink receiver devices are color coded blue. They are auto-insertable. They are tested for handling in static-controlled assembly processes (HBM). Cleaning, degreasing and post solder washing should be carried out using standard solutions compatible with both plastics and the environment. For example, recommended solutions for degreasing are alcohols (methyl, isopropyl and isobutyl). Acetone, ethyl acetate, phenol or similar solution based products are not permitted.

In the soldering process, non-halogenated water soluble fluxes are recommended. These products are not suitable for use in reflow solder processes (infrared/vapor-phase reflow). The dust plug should remain in place during soldering, washing and drying processes to avoid contamination of the active optical area of each part.

The Moisture Sensitivity Level (MSL) classification of this device is 2a according to JEDEC J-STD-020. The shelf life of an unopened MBB (Moisture Barrier Bag) is 24 months at $< 40\text{ }^{\circ}\text{C}$ and $< 90\text{ \% R.H.}$. Once the Moisture Barrier Bag is opened the devices can be either

- a) Stored in normal factory conditions $< 30\text{ }^{\circ}\text{C}$ and $< 60\text{ \% R.H.}$ for a maximum of 672 hours (4 Weeks) prior to soldering.
- b) Stored at $< 10\text{ \% R.H.}$ (Dry Cabinet).

PACKING INFORMATION

Components are packed in PVC anti-static tubes in moisture barrier bags. Bags should be opened only in static-controlled locations, and standard procedures should be followed for handling moisture sensitive components.

Table 7
PACKING INFORMATION

	Horizontal	Vertical
Components per Tube	40	40
Tube Length	515 mm	515 mm
Tube Height	16.2 mm	21.0 mm
Tube Depth	26.9 mm	30.8 mm
Tubes per Bag	5	5
Bags per Inner Carton	1	1
Inner Carton Length	630 mm	630 mm
Inner Carton Width	70 mm	70 mm
Inner Carton Height	105 mm	105 mm
Weight per Inner Carton, Complete	0.77 kg	0.92 kg
Components per Inner Carton	200	200
Inner Cartons per Outer Carton	10	10
Outer Carton Length	650 mm	650 mm
Outer Carton Width	235 mm	235 mm
Outer Carton Height	376 mm	376 mm
Weight per Outer Carton, Complete	8.15 kg	9.61 kg
Components per Outer Carton	2,000	2,000

For the most recent revision or further information please visit www.firecomms.com or contact the company directly at the following address, Firecomms Ltd, 2200 Airport Business Park, Cork, IRELAND. Copyright© 2004-2018 Firecomms. All rights reserved. Firecomms refers to Firecomms Limited and/or its subsidiaries. Firecomms assumes no responsibility for inaccuracies or omissions in the information contained in this document. Specifications are subject to change without notice. No patent rights are granted to any of the circuits described herein.