

FR10DxxR

DC-10 MBd RedLink® Fiber Optic Receiver

Datasheet



DESCRIPTION

Firecomms DC-10 MBd RedLink® receiver is a fully integrated photodiode and receiver IC. The receiver is housed in a miniature package to interface to plug-terminated lengths of Plastic Optic Fiber (POF) or 200 µm Plastic Clad Silica (PCS) fiber. When paired with the appropriate transmitter, the receiver is capable of delivering 10 MBd digital signals over fiber and operate in the temperature range of -40 °C to +85 °C. The device can operate from 5 V or 3.3 V DC power rails and can tolerate ± 10 % supply variation.

The receiver is a robust optical to electrical receiver with integrated pulse width distortion minimisation circuitry for reliable data transmission. The receiver features a push-pull TTL compatible CMOS output. It is available in inverting and non-inverting options.

AVAILABLE OPTIONS

Table 1

ORDERING INFORMATION / PART NUMBERS

Non-Inverting RedLink® 10 MBd Receiver Horizontal	FR10DHNR
Inverting RedLink® 10 MBd Receiver Horizontal	FR10DHIR
Non-Inverting RedLink® 10 MBd Receiver Vertical	FR10DVNR
Inverting RedLink® 10 MBd Receiver Vertical	FR10DVIR
Non-Inverting RedLink® 10 MBd Receiver Tilted	FR10DWNR
Inverting RedLink® 10 MBd Receiver Tilted	FR10DWIR



FEATURES

- Ideal for use with POF or PCS fiber
- Optimised for data rates of DC to 10 MBd
- Industrial Temperature Range -40 °C to +85 °C
- Dual 5 V and 3.3 V power supply with 10 % rail tolerance
- RoHS compliant and flame retardant (UL 94 V-0) housing
- Inverting and Non-Inverting options
- Horizontal, Vertical and 30° Tilted options
- Push Pull TTL Compatible CMOS output
- Ultra-low pulse width distortion to limit pulse distortion from burst mode data
- The form factor of the RedLink® family is compatible with the Versatile Link range of connectors and cables

APPLICATIONS

Table 2
APPLICATIONS

Application	Automation and Industrial Control. Serial Communications. Voltage Isolation.
Standard	Serial RS232, RS485, CAN-Bus, Modbus, PROFIBUS
Distance	50 meters Step Index POF ^[1] 300 meters with 200 µm PCS fiber ^[1]
Speed	DC to 10 MBd

Note: 1. Depending on the installation conditions

SPECIFICATIONS

Table 3
RECEIVER PIN DESCRIPTION

Pin	Name	Symbol
1	RECEIVER OUTPUT	V_O
2	RECEIVER GROUND	GND
3	RECEIVER VCC	V_{CC}
4	NO CONNECT ^[1]	NC
5	RETAINING PIN ^[2]	GND
8	RETAINING PIN ^[2]	GND

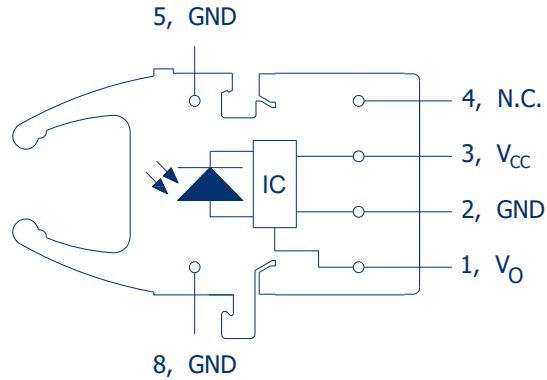

FIGURE 1
Receiver pin-out, top view

NOTE:

1. Pin 4 is electrically isolated internally. Pin 4 may be externally connected to pin 1 for board layout compatibility with existing designs. Otherwise, it is recommended pin 4 be grounded as in Figure 2.
2. Pins 5 and 8 are only used for mounting and retaining purposes. Connect both to ground.

RECOMMENDED APPLICATION CIRCUIT

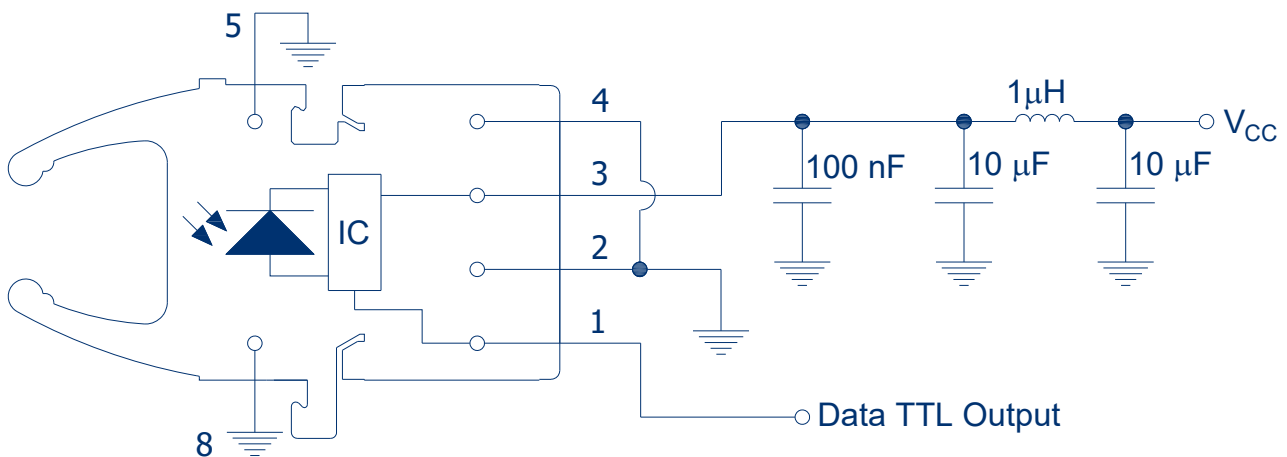

FIGURE 2
RedLink® receiver application circuit

GENERAL OPERATION FOR INVERTING RECEIVER

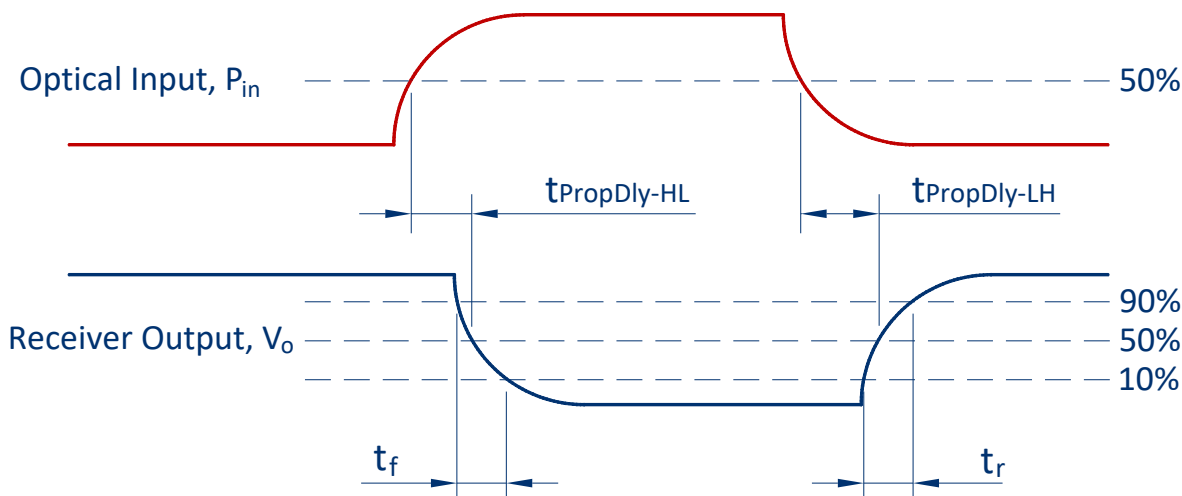

FIGURE 3
Receiver propagation delay and rise/fall time definitions for an inverting receiver output

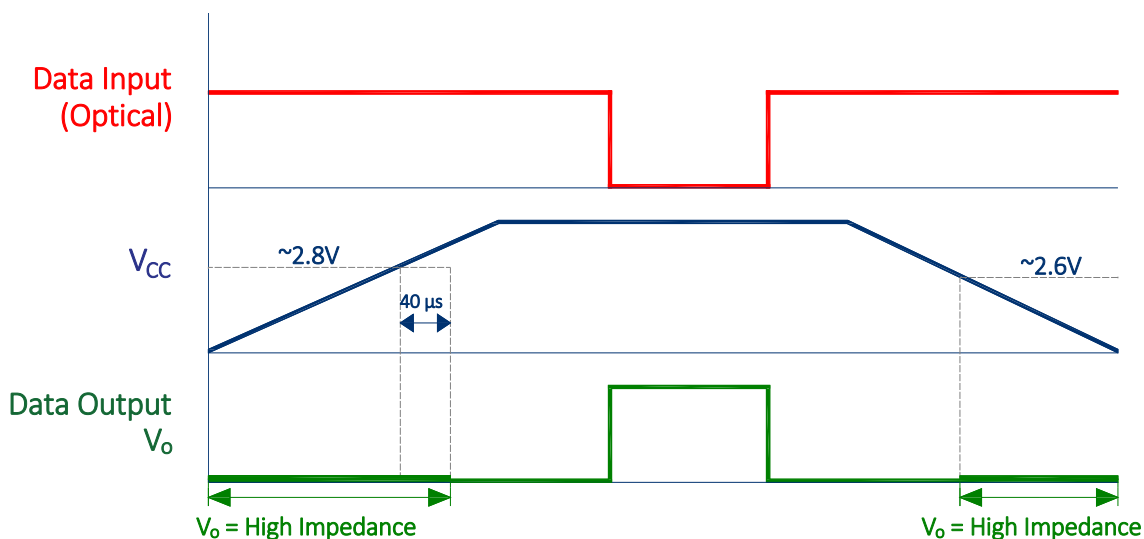

FIGURE 4
Inverting receiver output operation during power cycling

Operation of the Inverting parts FR10DxIR during power up, power down or power reset is illustrated above. During power up as V_{CC} rises to approximately 2.8 V, the output V_o is in a high impedance state. Within 40 μs of V_{CC} reaching 2.8 V the output V_o will change to the correct logic state which in the diagram above is logic low as there is light present and the output is inverted relative to the light input. On power down once V_{CC} drops below approximately 2.6 V then V_o changes immediately to a high impedance state.

GENERAL OPERATION FOR NON-INVERTING RECEIVER

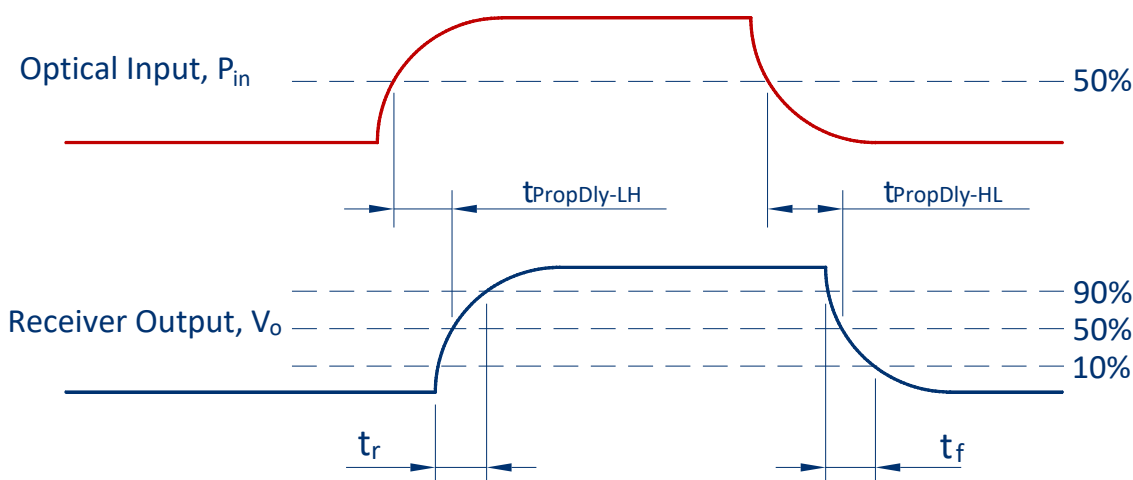

FIGURE 5
Receiver propagation delay and rise/fall time definitions for a non-inverting receiver output

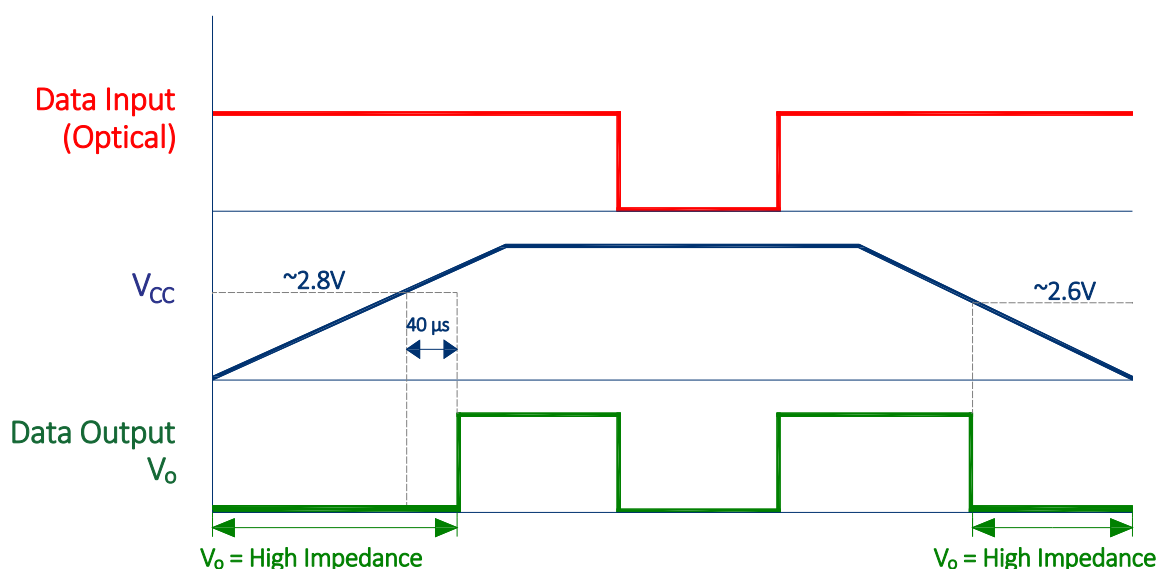

FIGURE 6
Non-inverting receiver output operation during power cycling

Operation of the Non-Inverting parts FR10DxNR during power up, power down or power reset is illustrated above. During power up as V_{CC} rises to approximately 2.8 V, the output V_o is in a high impedance state. Within 40 μs of V_{CC} reaching 2.8 V the output V_o will change to the correct logic state which in the diagram above is logic high as there is light present and the output is non-inverting. On power down once V_{CC} drops below approximately 2.6 V then V_o changes immediately to a high impedance state.

SPECIFICATIONS

Table 4
REGULATORY COMPLIANCE

Parameter	Symbol	Standard	Level
Electrostatic Discharge, Human Body Model (contact ESD)	HBM	Mil-STD-883	Level 2 (4 kV)
Radiated Emissions Immunity	Vm ⁻¹	IEC 61000-4-3	15 Vm ⁻¹
UL Certification	UL	60950-1	File No. E362227
Storage Compliance	MSL	J-STD-020	2a (4 week floor life)
Restriction of Hazardous Substances Directive	RoHS	Directive 2011/65/EU Incl. Amendment 2015/863	Certified compliant

Table 5
ABSOLUTE MAXIMUM RATINGS

These are the absolute maximum ratings at or beyond which the FOT can be expected to be damaged. These ratings are stress ratings only.

Notes

1. 260 °C for 10 seconds, one time only, at least 2.2 mm away from lead root
2. Applying conditions above absolute maximum ratings is destructive to the device. Functional operation of the device at conditions between maximum operating conditions (5.5 V) and absolute maximum ratings is not implied. Extended exposure to stresses above recommended operating conditions will have an effect on device reliability

Parameter	Symbol	Minimum	Maximum	Unit
Storage Temperature	T _{stg}	-40	+85	°C
Operating Temperature	T _{op}	-40	+85	°C
Soldering Temperature ^[1]	T _{slid}		+260	°C
Receiver Supply Voltage ^[2]	V _{cc}	-0.5	+7	V
Receiver Output Current	I _o	-16	+16	mA

SPECIFICATIONS

Table 6
RECEIVER ELECTRICAL AND OPTICAL CHARACTERISTICS

Test Conditions:

1. Wake up Delay is the delay from $V_{CC} > 2.75\text{ V}$ to when the output will respond correctly to optical input. Output is held in tristate before this time
3. Test data was validated using a transmitter with an emission wavelength between 635 and 680 nm with a 5 ns rise and fall time, over the full temperature range of $-40\text{ }^{\circ}\text{C}$ to $+85\text{ }^{\circ}\text{C}$, and over both supply rail voltage options of 5 V and $3.3\text{ V} \pm 10\%$ and over the input optical received power as specified by PH and PL. Input power levels are for peak (not average) optical input levels. For 50% duty cycle data, peak optical power is twice the average optical power. Data referred to as typical are rated at $+25\text{ }^{\circ}\text{C}$
4. Optical signal from the recommended Transmitter circuit.
5. Testing in the recommended receiver circuit ($R_L = 50\text{ k}\Omega$, $C_L(\text{total}) = 15\text{ pF}$)
6. Pulse Width Distortion (PWD) for Optical Input of 10 MBd, NRZ 2⁷-1 (PRBS7) data, resulting in a BER $\leq 10^{-9}$.
7. If data rate $< 1\text{ MBd}$, then the pulse width distortion = 1st pulse PWD
8. Propagation Delay Skew is a measure of the part to part variation of the Propagation Delay on the first pulse response when parts are all tested in the same conditions, an optical power accuracy of $\pm 1\text{ dBm}$, a power supply variance less than 5%, a temperature variance of less than $5\text{ }^{\circ}\text{C}$, and the same environmental conditions (humidity, PCB layout etc.)
9. The performance of the receiver as given in Table 6 has been characterized for transmitters operating between 635 and 680 nm. The receiver will nevertheless respond to optical sources operating from the visible to near infra-red regions although the precise performance may differ from that given in Table 6 depending upon the precise wavelength and rise/fall time characteristics of the optical source used.

Parameter	Symbol	Min	Typical	Max	Unit	Test Condition
Supply Current	I_{CC}		13	16	mA	[2,3,4]
Wake Up Delay (power up)	$t_{\text{power-on}}$		40		μs	[1]
High Level Output Voltage	V_{OH}	$V_{CC} - 0.05$		V_{CC}	V	$I_{OH\text{-max}} = 40\text{ }\mu\text{A}$, [2]
Low Level Output Voltage	V_{OL}	0		0.1	V	$I_{OL\text{-max}} = 1.6\text{ mA}$, [2]
POF Optical Power High	P_H	-22		+2	dBm	[2,3], 1 mm POF
POF Optical Power Low	P_L			-40	dBm	[2,3], 1 mm POF
PCS Optical Power High	P_H	-24		0	dBm	[2,3], 200 μm PCS
PCS Optical Power Low	P_L			-42	dBm	[2,3], 200 μm PCS
Data Rate		DC		10	MBd	Min UI = 100 ns Max f = 5 MHz
Output Rise Time (10 % - 90 %)	t_r	4	8	12	ns	[2,3,4]
Output Fall Time (90 % - 10 %)	t_f	4	8.5	13	ns	[2,3,4]
Pulse Width Distortion	PWD	-10		+10	ns	[2,3,4,5]
1 st Pulse, Pulse Width Distortion	PWD_{init}	-10		+12	ns	[2,3,4,5,6]
Propagation Delay	$t_{\text{PropDly-HL}}$			55	ns	[2,3,4]
	$t_{\text{PropDly-LH}}$			55	ns	[2,3,4]
Propagation Delay Skew	$t_{\text{PropDly-SKEW}}$			20	ns	[7]
Optical Sensitivity Range	λ_R	400		900	nm	[8]

MECHANICAL DATA, HORIZONTAL

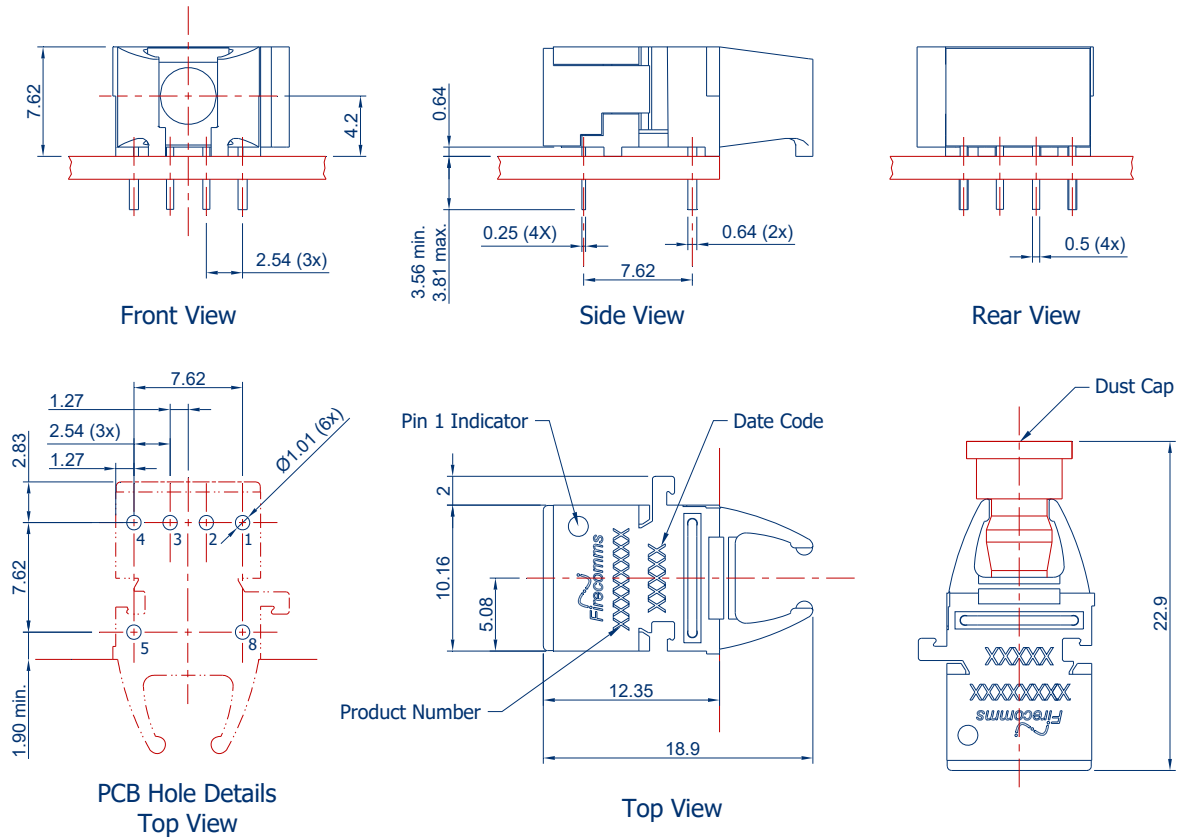

FIGURE 7
Mechanical dimensions of RedLink® horizontal connectors and PCB footprint, which is a top view
General dimensional tolerance is ± 0.2 mm

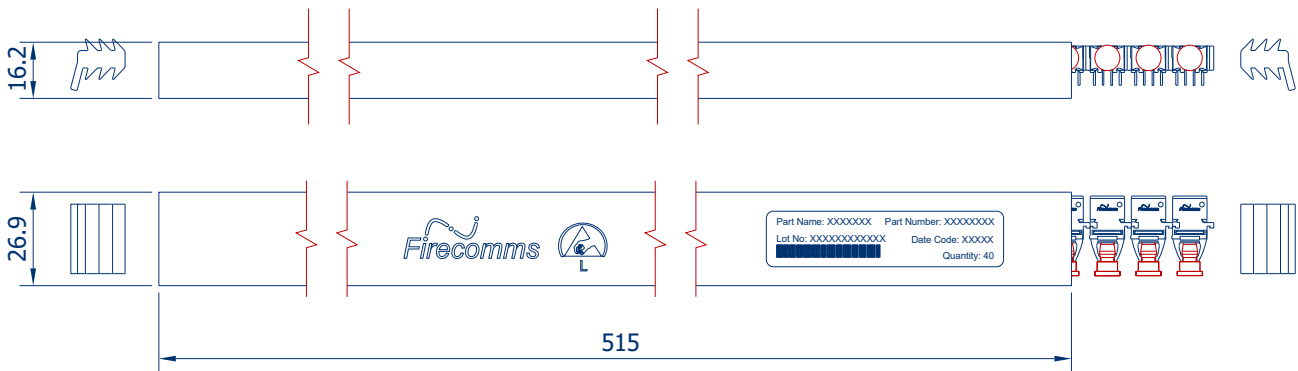

FIGURE 8
Packing tube for Firecomms RedLink® horizontal connectors

MECHANICAL DATA, VERTICAL

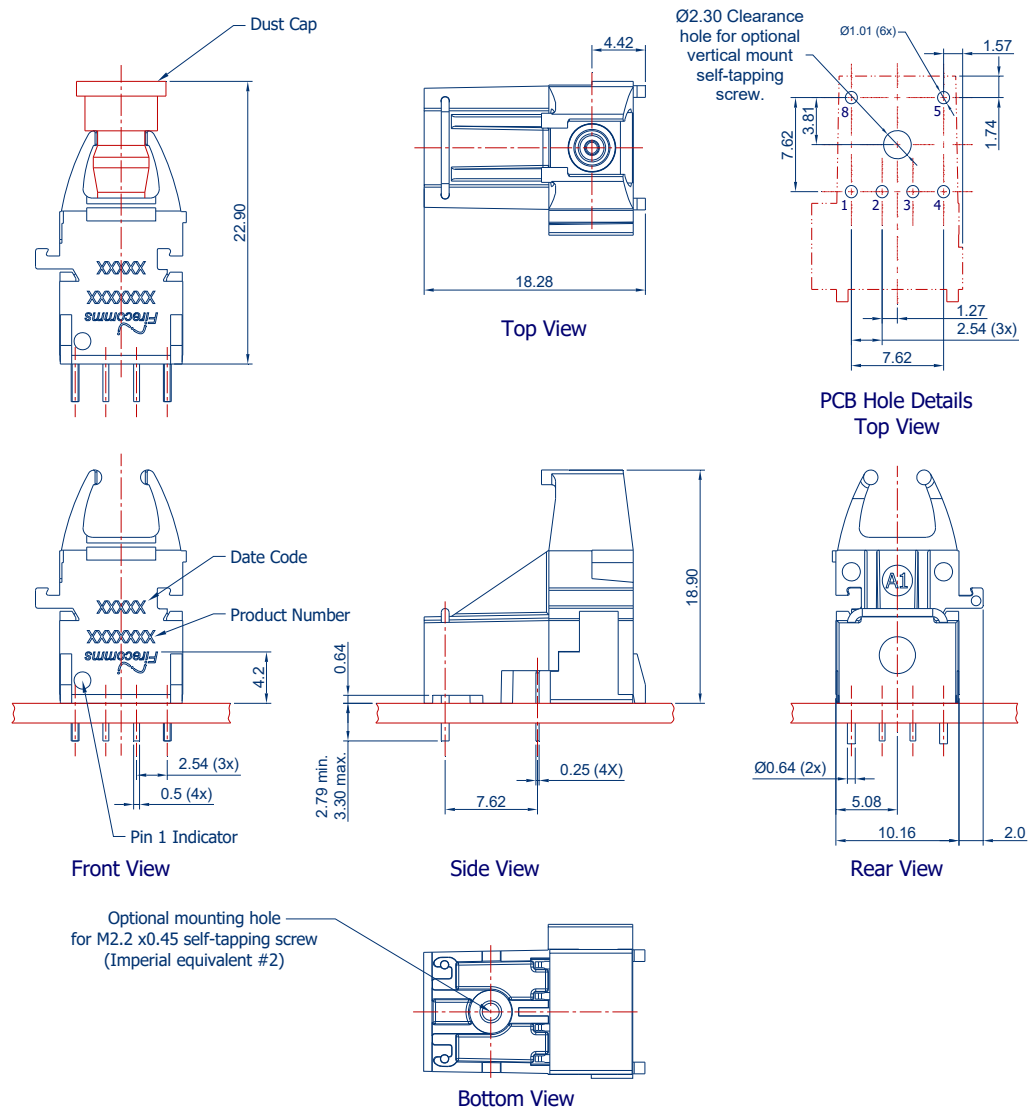

FIGURE 9
Mechanical dimensions of RedLink® vertical connectors and PCB footprint, which is a top view
General dimensional tolerance is ± 0.2 mm

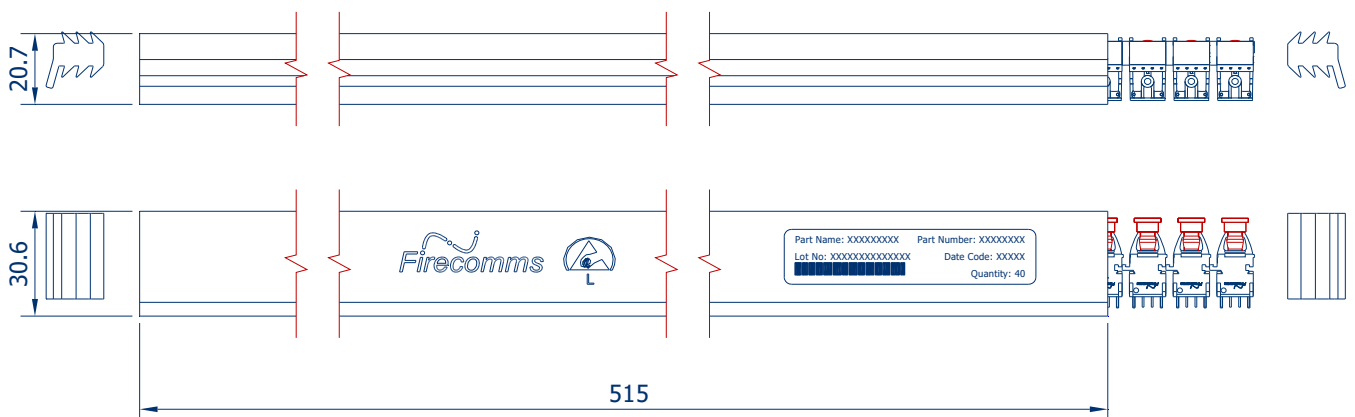

FIGURE 10
Packing tube for Firecomms RedLink® vertical connectors

MECHANICAL DATA, 30° TILTED

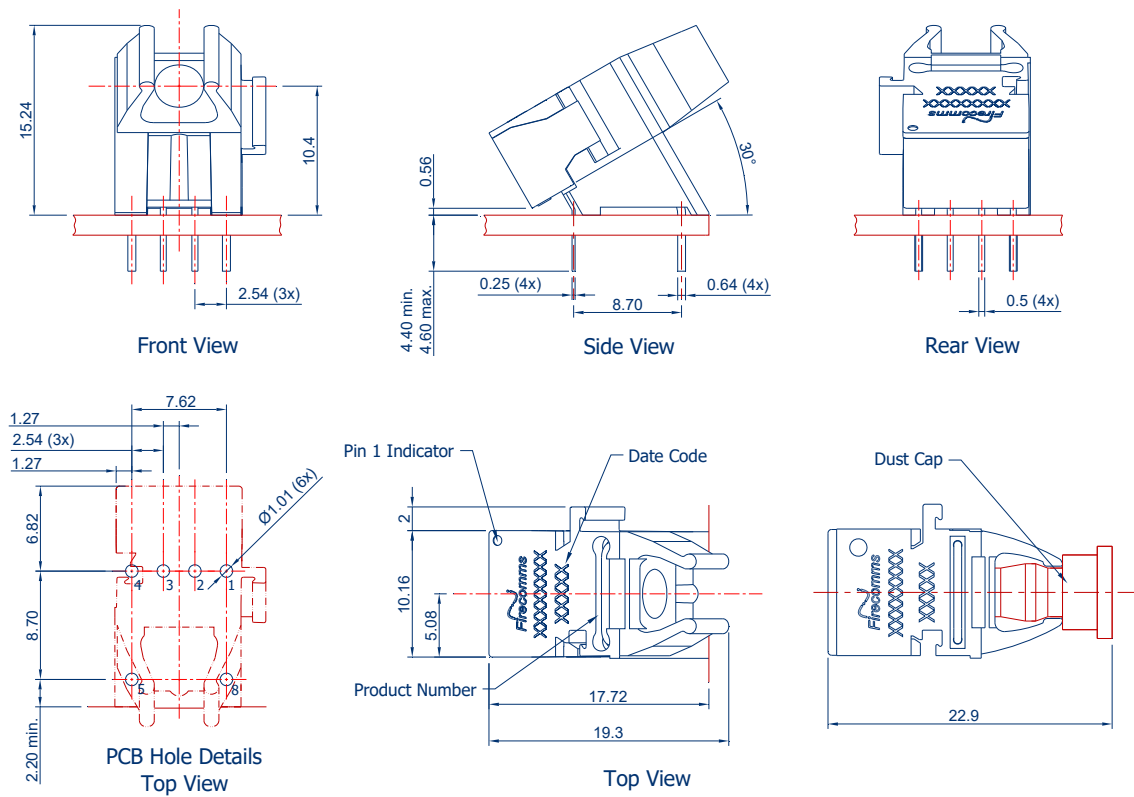

FIGURE 11
Mechanical dimensions of RedLink® tilted connectors and PCB footprint, which is a top view
 General dimensional tolerance is ± 0.2 mm

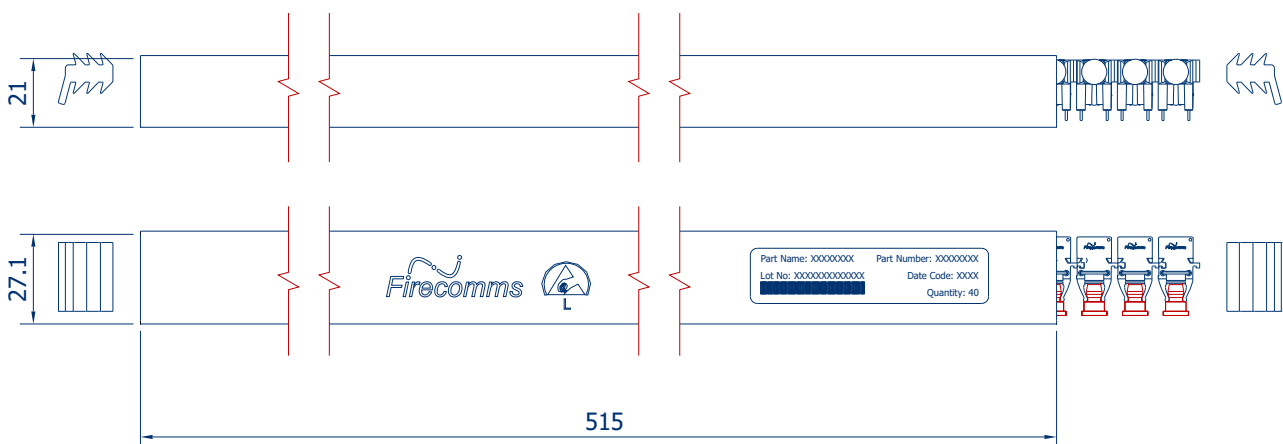

FIGURE 12
Packing tube for Firecomms RedLink® tilted connectors

PART HANDLING

Firecomms RedLink® connectors are auto-insertable and tested for handling in static-controlled assembly processes (Human Body Model - HBM). Cleaning, degreasing and post solder washing should be carried out using standard solutions compatible with both plastics and the environment. For example, recommended solutions for degreasing are alcohols (methyl, isopropyl and isobutyl). Acetone, ethyl acetate, phenol or similar solution-based products are not permitted.

In the soldering process, non-halogenated water-soluble fluxes are recommended. RedLink® connectors are not suitable for use in reflow solder processes (infrared/vapor-phase reflow). The dust plug should remain in place during soldering, washing and drying processes to avoid contamination of the active optical area of each part.

The Moisture Sensitivity Level (MSL) classification of this device is 2a according to JEDEC J-STD-020.

The shelf life of an unopened MBB (Moisture Barrier Bag) is 24 months at < 40 °C and < 90 % R.H.

Once the Moisture Barrier Bag is opened, the devices can be either;

- a) Stored in normal factory conditions < 30 °C and < 60 % R.H. for a maximum of 672 hours (4 Weeks) prior to soldering
- b) Stored at < 10 % R.H. (Dry Cabinet)

PACKING INFORMATION

Components are packed in PVC anti-static tubes and in moisture barrier bags. Bags should be opened only in static-controlled locations, and standard procedures should be followed for handling moisture sensitive components.

Table 7
PACKING INFORMATION

	Horizontal	Vertical	Tilted
Components per Tube	40	40	40
Tube Length	515 mm	515 mm	515 mm
Tube Height	16.2 mm	20.7 mm	21 mm
Tube Depth	26.9 mm	30.6 mm	27.1 mm
Tubes per Bag	5	5	5
Bags per Inner Carton	1	1	1
Inner Carton Length	630 mm	630 mm	630 mm
Inner Carton Width	70 mm	70 mm	70 mm
Inner Carton Height	105 mm	105 mm	105 mm
Weight per Inner Carton, Complete	0.77 kg	0.92 kg	0.92 kg
Components per Inner Carton	200	200	200
Inner Cartons per Outer Carton	10	10	10
Outer Carton Length	650 mm	650 mm	650 mm
Outer Carton Width	235 mm	235 mm	235 mm
Outer Carton Height	376 mm	376 mm	376 mm
Weight per Outer Carton, Complete	8.13 kg	9.60 kg	9.60 kg
Components per Outer Carton	2,000	2,000	2,000

For the most recent revision or further information please visit www.firecomms.com or contact the company directly at the following address, Firecomms Ltd, 2200 Airport Business Park, Cork, IRELAND. Copyright© 2004-2025 Firecomms. All rights reserved. Firecomms refers to Firecomms Limited and/or its subsidiaries. Firecomms assumes no responsibility for inaccuracies or omissions in the information contained in this document. Specifications are subject to change without notice. No patent rights are granted to any of the circuits described herein.