

# FR05DxIR

## DC-5 MBd Dual Supply Voltage RedLink® Receiver

### Datasheet



### DESCRIPTION

Firecomms DC to 5 MBd Dual supply voltage RedLink® receiver is based on a fully integrated photo-diode with TIA and limiting amplifier.

Housed in non-conducting plastic RedLink® connector housings, the receiver is blue in colour. The housing is compatible with the Versatile Link style fiber plug, and is designed primarily for use with Plastic Optic Fiber (POF).

The receiver operates equally at both the standard 3.3 V and 5 V DC supply rail voltages. It operates over the industrial temperature range of -40 °C to +85 °C supporting many industrial applications where a reliable command and control response is required in electrically harsh environments.

The integrated silicon gives enhanced immunity to EMI/EMC from the local environment making the unit ideal for use in electrically noisy applications. The receiver has a single push-pull logic output compatible with TTL/CMOS.

### AVAILABLE OPTIONS

Table 1

#### ORDERING INFORMATION / PART NUMBERS

5 MBd Horizontal Package Inverting, TTL	FR05DHIR
5 MBd Vertical Package Inverting, TTL	FR05DVIR
5 MBd Tilted Package Inverting, TTL	FR05DWIR

### FEATURES

- Designed for use with Plastic Optic Fiber (POF)
- Optimised for data rates from DC to 5 MBd
- Industrial Temperature Range -40 °C to +85 °C
- Dual 5 V and 3.3 V power supply operation
- RoHS compliant and flame retardant (UL 94 V-0) housing
- Horizontal, Vertical and 30° Tilted options
- Push Pull TTL Compatible CMOS output
- Low pulse width distortion
- The form factor of the RedLink® family is compatible with the Versatile Link range of connectors and cables

### APPLICATIONS

Table 2  
APPLICATIONS

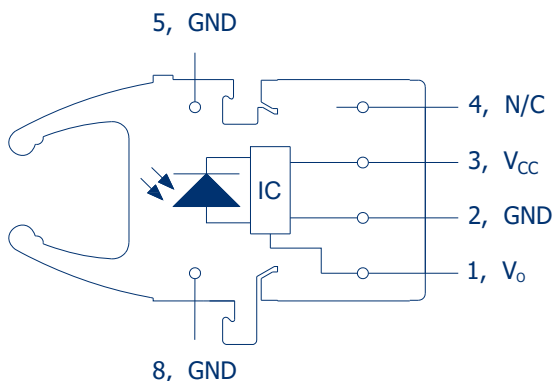
Application	Automation and Industrial Control. Serial Communications. Voltage Isolation.
Standard	Serial RS232, RS485, CAN-Bus, Modbus, PROFIBUS
Distance	50 meters Step Index POF <sup>[1]</sup> 300 meters with 200 µm PCS fiber <sup>[1]</sup>
Speed	DC to 5 MBd

Note: 1 Depending on the installation condition

## SPECIFICATIONS

**Table 3**  
**RECEIVER PIN DESCRIPTION**

Pin	Name	Symbol
1	RECEIVER OUTPUT	$V_o$
2	RECEIVER GROUND	GND
3	RECEIVER $V_{CC}$	$V_{CC}$
4	NO CONNECT <sup>(a)</sup>	NC
5	RETAINING PIN <sup>(b)</sup>	GND
8	RETAINING PIN <sup>(b)</sup>	GND



**FIGURE 1**  
**Receiver pin-out, top view**

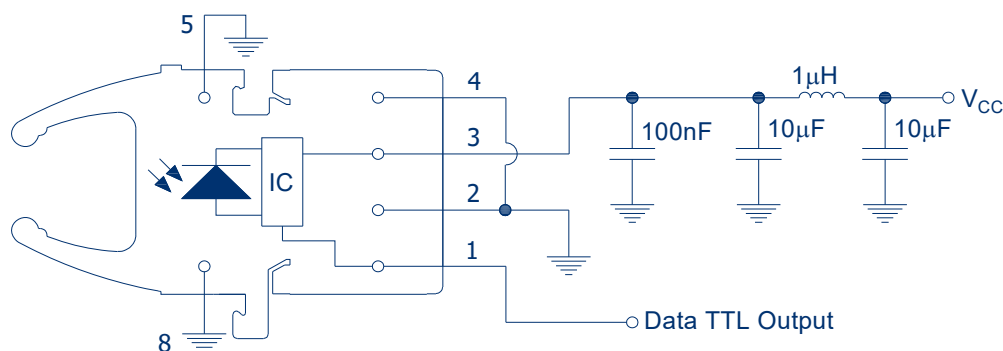
**NOTE:**

- a) Pin 4 is electrically isolated internally. Pin 4 may be externally connected to pin 1 for board layout compatibility with existing designs. Otherwise, it is recommended pin 4 be grounded as in Figure 2.
- b) Pins 5 and 8 are only used for mounting and retention purposes. It is recommended that pins 5 and 8 be connected to ground.

**Table 4**  
**REGULATORY COMPLIANCE**

Parameter	Symbol	Standard	Level
Electrostatic Discharge, Human Body Model (contact ESD)	HBM	Mil-STD-883	Level 2 (4 kV)
UL Certification	UL	60950-1	File No. E362227
Storage Compliance	MSL	J-STD-020	2a (4-week floor life)
Restriction of Hazardous Substances Directive	RoHS	Directive 2011/65/EU Incl. Amendment 2015/863	Certified compliant

## RECOMMENDED APPLICATION CIRCUIT



**FIGURE 2**  
**Recommended receiver application circuit**

## SPECIFICATIONS

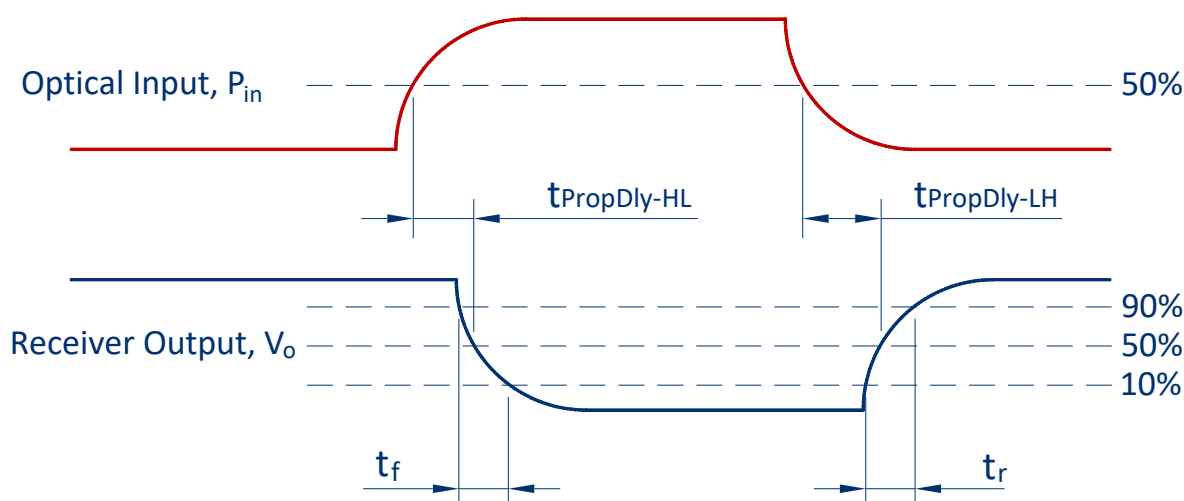
**Table 5**  
**ABSOLUTE MAXIMUM RATINGS**

*These are the absolute maximum ratings at or beyond which the FOT can be expected to be damaged. These ratings are stress ratings only.*

**Notes:**

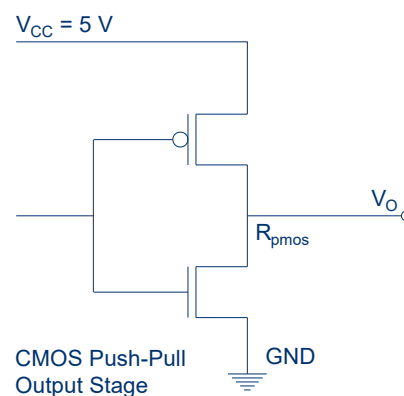
1. 260°C for 10 seconds, one time only, at least 2.2 mm away from lead root
2. Applying conditions above absolute maximum ratings is destructive to the device. Functional operation of the device at conditions between maximum operating conditions (5.5 V) and absolute maximum ratings is not implied. Extended exposure to stresses above recommended operating conditions will have an effect on device reliability.

Parameter	Symbol	Minimum	Maximum	Unit
Storage Temperature	T <sub>stg</sub>	-40	+85	°C
Operating Temperature	T <sub>op</sub>	-40	+85	°C
Soldering Temperature <sup>[1]</sup>	T <sub>slid</sub>		+260 <sup>[1]</sup>	°C
Supply Voltage <sup>[2]</sup>	V <sub>cc</sub>	-0.5	+7	V
Rx Output Current	I <sub>o</sub>	-16	+16	mA
Storage Compliance	MSL		2a	J-STD-020



**FIGURE 3**  
Receiver propagation delay and rise/fall time definitions as per application circuit of Figure 2.

This Receiver has an output stage that is a standard CMOS push-pull design. It is suitable for operation with standard 5 V and 3.3 V CMOS logic ICs. It is not an open collector stage. It is not compatible with voltages higher than 5.5 V.



**FIGURE 4** Receiver CMOS Push-Pull output stage

## SPECIFICATIONS

**Table 6**  
**RECEIVER ELECTRICAL AND OPTICAL CHARACTERISTICS**

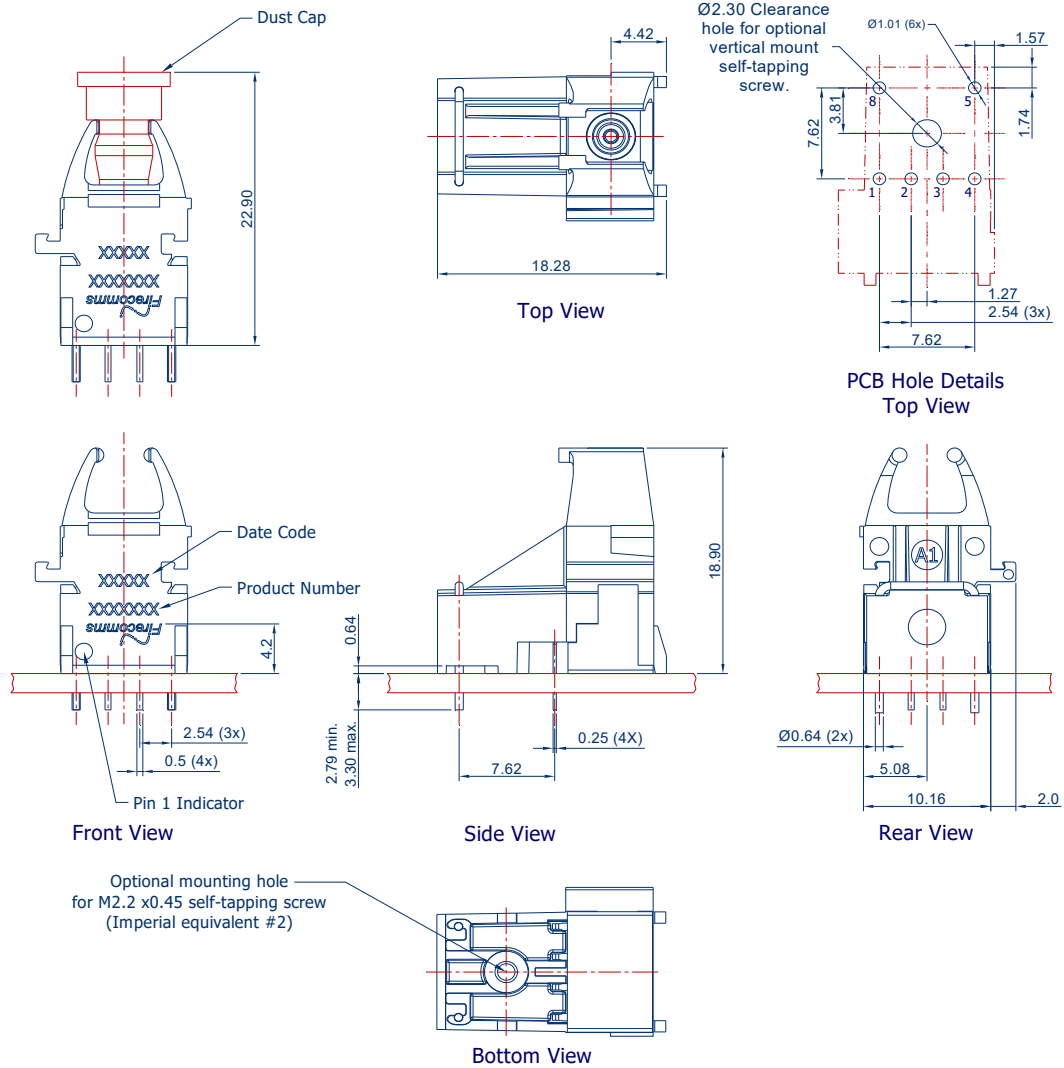
**Test Conditions:**

1. Wake up Delay is the delay from  $V_{CC} > 2.75$  V to when the output will respond correctly to optical input. Output is held in tristate before this time.
2. Test data was validated using a transmitter with a 5ns rise and fall time, over the full temperature range of  $-40$  °C to  $+85$  °C, and over both supply rail voltage options of 5 V and  $3.3$  V  $\pm$  10% and over the input optical received power as specified by  $P_H$  and  $P_L$ . Input power levels are for peak (not average) optical input levels. For 50% duty cycle data, peak optical power is twice the average optical power. Data referred to as typical are rated at  $+25$  °C.
3. Optical signal from the recommended Transmitter circuit.
4. Testing in the recommended receiver circuit ( $R_L = 50$  k $\Omega$ ,  $C_{L(total)} = 15$  pF)
5. PWD for Optical Input of 5 MBd, NRZ 2<sup>7</sup>-1 (PRBS7) data, resulting in a BER  $\leq 10^{-9}$ .
6. If data rate  $< 1$  MBd, then the pulse width distortion = 1<sup>st</sup> pulse PWD
7. Propagation Delay Skew is a measure of the part-to-part variation of the Propagation delay on the first edge response when all parts are tested in the same conditions, an optical power accuracy of  $\pm 1$  dBm, a power supply variance less than 5%, a temperature variance of less than 5 °C, and the same environmental conditions (humidity, PCB layout etc).

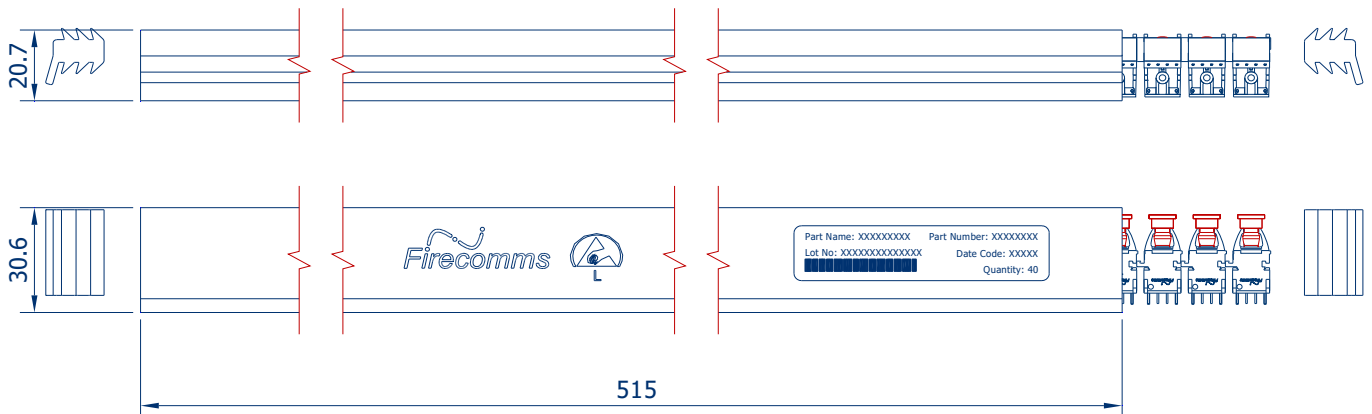
Parameter	Symbol	Min	Typical	Max	Unit	Test Condition
Supply Current	$I_{CC}$		13	16	mA	[2,3,4]
Wake Up Delay (power up)	$t_{power-on}$		40		$\mu$ s	[1]
High Level Output Voltage	$V_{OH}$	$V_{CC} - 0.05$		$V_{CC}$	V	$I_{OH-max} = 40$ $\mu$ A, [2]
Low Level Output Voltage	$V_{OL}$	0		0.1	V	$I_{OL-max} = 1.6$ mA, [2]
POF Optical Power High	$P_H$	-22		+2	dBm	[2,3], 1 mm 0.5 NA POF
POF Optical Power Low	$P_L$			-40	dBm	[2,3], 1 mm 0.5 NA POF
PCS Optical Power High	$P_H$	-24		+2	dBm	[2,3], 200 $\mu$ m PCS
PCS Optical Power Low	$P_L$			-42	dBm	[2,3], 200 $\mu$ m PCS
Data Rate		DC		5	MBd	Min UI = 200 ns, Max f = 2.5 MHz
Output Rise Time (10 % - 90 %)	$t_r$	4	8	12	ns	[2,3,4]
Output Fall Time (90 % - 10 %)	$t_f$	4	9	13	ns	[2,3,4]
Pulse Width Distortion	PWD	-10		+10	ns	[2,3,4,5]
Pulse Width Distortion 1 <sup>st</sup> pulse	$PWD_{init}$	-10		+12	ns	[2,3,4,5,6]
Propagation Delay	$t_{PropDly-HL}$			55	ns	[2,3,4]
	$t_{PropDly-LH}$			55	ns	[2,3,4]
Propagation Delay Skew	$t_{PropDly-SKEW}$			20	ns	[7]



**MECHANICAL DATA, VERTICAL**

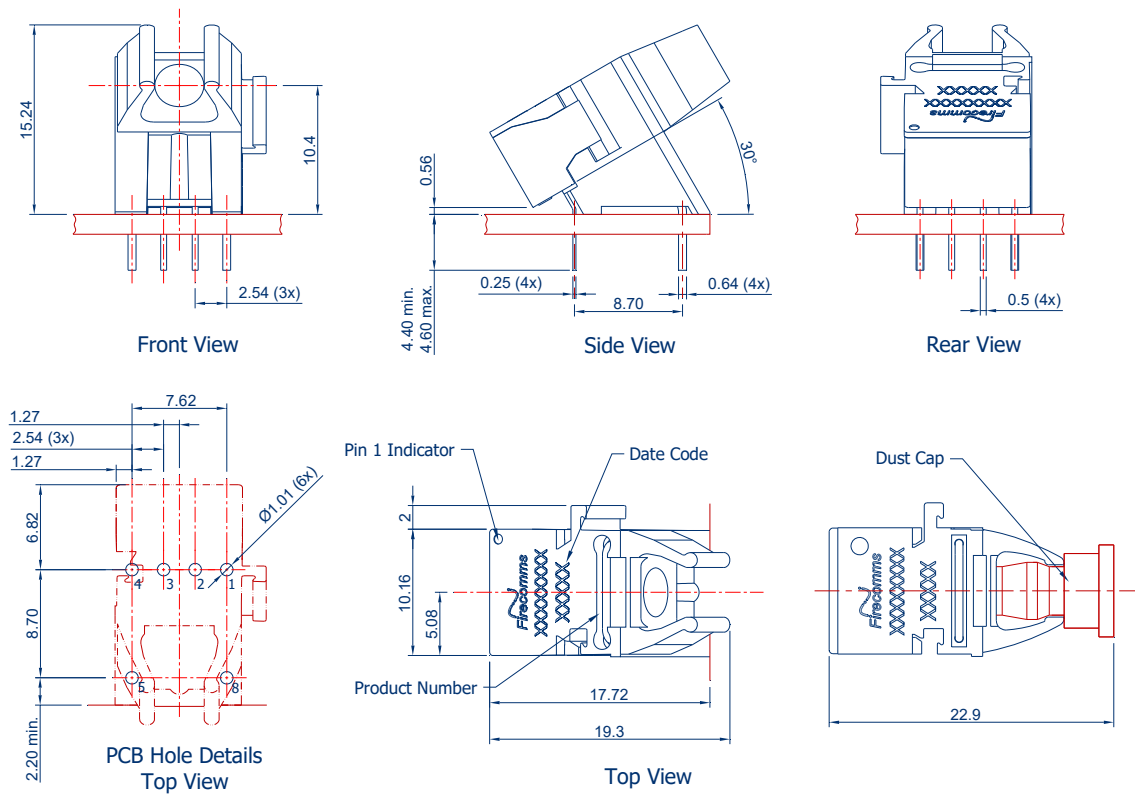


**FIGURE 7**  
Mechanical dimensions of RedLink® vertical connectors and PCB footprint, which is a top view  
General dimensional tolerance is ± 0.2 mm

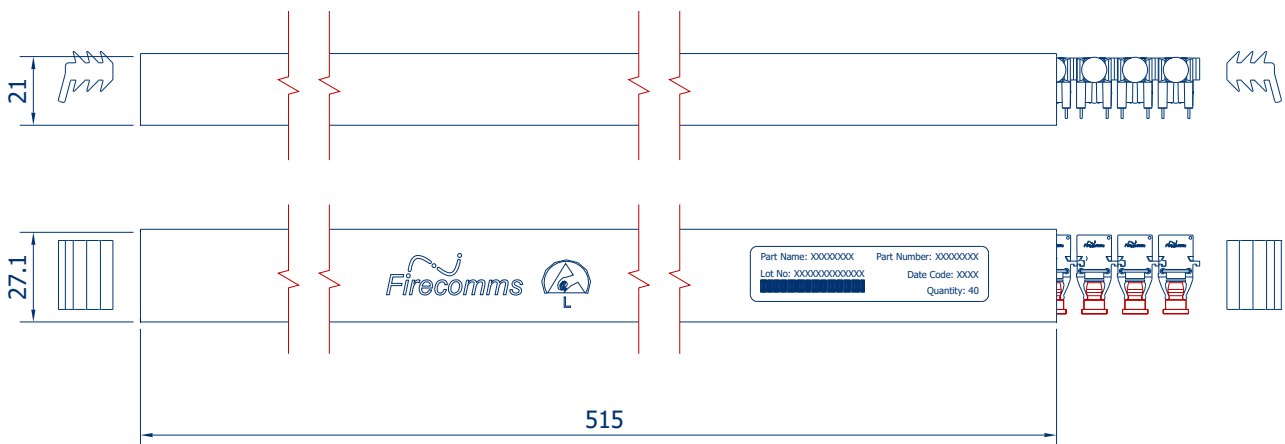


**FIGURE 8**  
Packing tube for Firecomms RedLink® vertical connectors

## MECHANICAL DATA, 30° TILTED



**FIGURE 9**  
**Mechanical dimensions of RedLink® tilted connectors and PCB footprint, which is a top view**  
 General dimensional tolerance is  $\pm 0.2$  mm



**FIGURE 10**  
**Packing tube for Firecomms RedLink® tilted connectors**

## PART HANDLING

Firecomms RedLink® connectors are auto-insertable and tested for handling in static-controlled assembly processes (Human Body Model - HBM). Cleaning, degreasing and post solder washing should be carried out using standard solutions compatible with both plastics and the environment. For example, recommended solutions for degreasing are alcohols (methyl, isopropyl and isobutyl). Acetone, ethyl acetate, phenol or similar solution-based products are not permitted.

In the soldering process, non-halogenated water-soluble fluxes are recommended. RedLink® connectors are not suitable for use in reflow solder processes (infrared/vapor-phase reflow). The dust plug should remain in place during soldering, washing and drying processes to avoid contamination of the active optical area of each part.

The Moisture Sensitivity Level (MSL) classification of this device is 2a according to JEDEC J-STD-020.

The shelf life of an unopened MBB (Moisture Barrier Bag) is 24 months at < 40 °C and < 90 % R.H.

Once the Moisture Barrier Bag is opened, the devices can be either;

- a) Stored in normal factory conditions < 30 °C and < 60 % R.H. for a maximum of 672 hours (4 Weeks) prior to soldering
- b) Stored at < 10 % R.H. (Dry Cabinet)

## PACKING INFORMATION

Components are packed in PVC anti-static tubes and in moisture barrier bags. Bags should be opened only in static-controlled locations, and standard procedures should be followed for handling moisture sensitive components.

**Table 7**  
**PACKING INFORMATION**

	Horizontal	Vertical	Tilted
Components per Tube	40	40	40
Tube Length	515 mm	515 mm	515 mm
Tube Height	16.2 mm	20.7 mm	21 mm
Tube Depth	26.9 mm	30.6 mm	27.1 mm
Tubes per Bag	5	5	5
Bags per Inner Carton	1	1	1
Inner Carton Length	630 mm	630 mm	630 mm
Inner Carton Width	70 mm	70 mm	70 mm
Inner Carton Height	105 mm	105 mm	105 mm
Weight per Inner Carton, Complete	0.77 kg	0.92 kg	0.92 kg
Components per Inner Carton	200	200	200
Inner Cartons per Outer Carton	10	10	10
Outer Carton Length	650 mm	650 mm	650 mm
Outer Carton Width	235 mm	235 mm	235 mm
Outer Carton Height	376 mm	376 mm	376 mm
Weight per Outer Carton, Complete	8.13 kg	9.60 kg	9.60 kg
Components per Outer Carton	2,000	2,000	2,000

For the most recent revision or further information please visit [www.firecomms.com](http://www.firecomms.com) or contact the company directly at the following address, Firecomms Ltd, 2200 Airport Business Park, Cork, IRELAND. Copyright© 2004-2025 Firecomms. All rights reserved. Firecomms refers to Firecomms Limited and/or its subsidiaries. Firecomms assumes no responsibility for inaccuracies or omissions in the information contained in this document. Specifications are subject to change without notice. No patent rights are granted to any of the circuits described herein.