

FP-00C-RD0, FP-00C-SD0 Duplex Non-Latching Plug Duplex Latching Plug

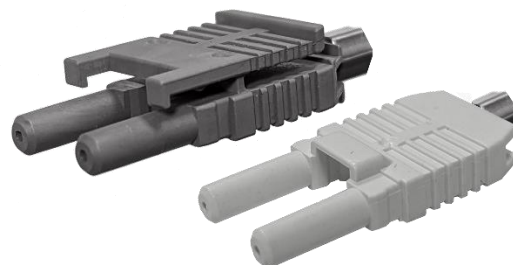

Datasheet



DESCRIPTION

Firecomms duplex friction non-latching plug offers a fast and secure link providing a moderate retention force using plastic optical fiber (POF).

Firecomms duplex latching plug offers robust performance for applications requiring high retention force. The plug is suitable for use with 2.2 mm plastic optical fiber (POF).

The latching mechanism provides a securely mated fit once inserted into a RedLink® connector. Applying pressure to the rear of the plug releases the latching mechanism. This allows for easy removal of the plug from the connector.

The Firecomms duplex latching and the friction non-latching plug are both compatible with horizontal, vertical, and tilted housings.

FEATURES

- Cost-effective, rugged optical links.
- Latching plug is suitable for applications with high vibration.
- Compatible with RedLink® and Versatile Link fiber optic transmitters and receivers.

APPLICATIONS

- Control links within high voltage electrical control equipment.
- Data communication where extreme immunity to EMI is required.
- Links between equipment that requires electrical isolation to be maintained.
- Rugged links in hostile environments.

Ordering Information

Part Number	Name	Description
FP-00C-RD0	RedLink® Duplex Non-Latching Plug, White	2.2 mm white non-latching duplex plug and crimp ring with 1 mm core
FP-00C-SD0	RedLink® Duplex Latching Plug, Grey	2.2 mm grey latching simplex plug and crimp ring with 1 mm core

SPECIFICATIONS

Duplex Non-Latching Plug Specifications

Parameter	Symbol	Min	Typical	Max	Unit
Storage Temperature	T_{stg}	-40		+85	°C
Operating Temperature	T_{op}	-40		+85	°C
Installation Temperature	T_i	0		+70	°C
Retention Force, Connector to Transceiver (+25°C)	F_R	7	12		N
Retention Force, Connector to Transceiver (-40°C + 85°C)	F_R	4			N
Insertion Force, Connector to Transceiver (+25°C)	F_i		13	46	N
Durability, Mating Cycles		500			
Fixing Method	Crimp				

Duplex Latching Plug Specifications

Parameter	Symbol	Min	Typical	Max	Unit
Storage Temperature	T_{stg}	-40		+85	°C
Operating Temperature	T_{op}	-40		+85	°C
Installation Temperature	T_i	0		+70	°C
Retention Force, Connector to Transceiver (+25°C)	F_R	50	80		N
Retention Force, Connector to Transceiver (-40°C + 85°C)	F_R	15			N
Insertion Force, Connector to Transceiver (+25°C)	F_i		22	51	N
Durability, Mating Cycles		500			
Fixing Method	Crimp				

MECHANICAL DIMENSIONS

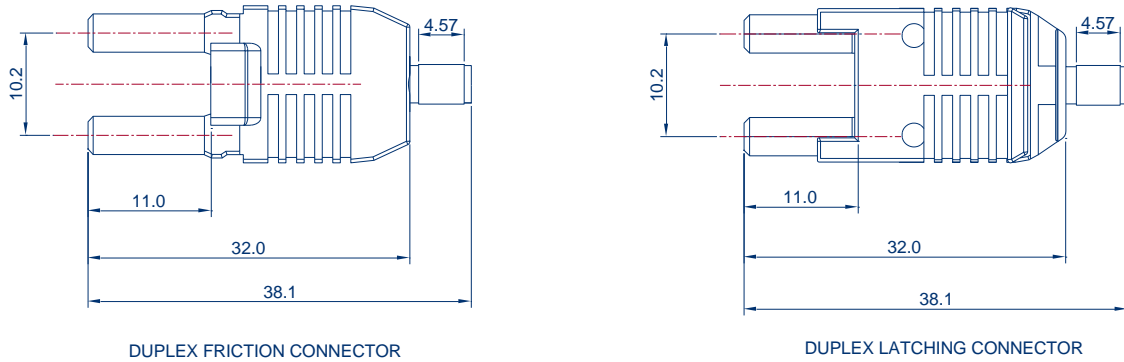

FIGURE 1. Duplex Non-Latching and Latching Plug mechanical dimensions

CONNECTOR AND CABLE ASSEMBLY AND POLISHING

Cable Stripping

Strip off approximately 3 mm of the outer jacket from the 2.2 mm POF cable.

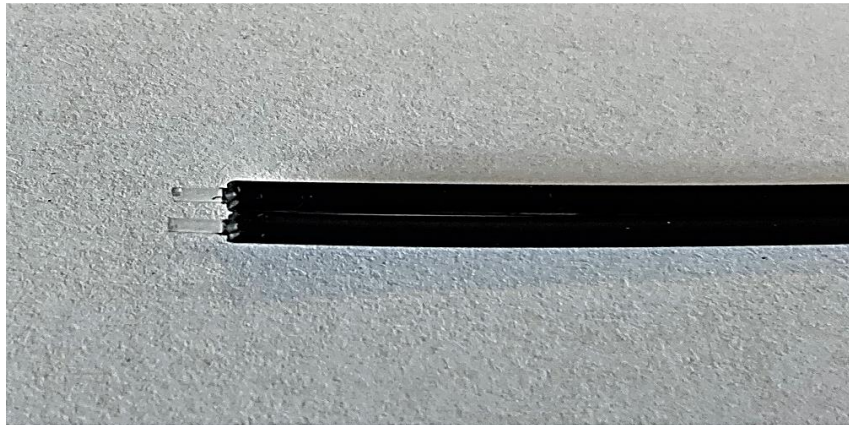

FIGURE 2. Jacket Strip Length 3 mm

In order to strip the jacket from the POF, insert both parts of cable separately into the simplex hole on the Firecomms POF cutter (PC-220F-410). After insertion, twist the cutter 360 degrees to cut the jacket and pull out the cable to reveal the exposed POF core.



FIGURE 3. Jacket Stripper on Firecomms POF cutter

POF Insertion

Insert the stripped POF cable into the backside of the connector until the mechanical stop is reached. Approximately 1.5 mm of the POF internal core should protrude from the top of the connector.

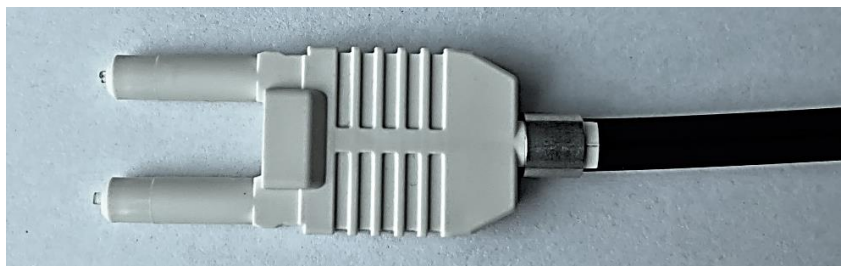

FIGURE 4. Cable and Connector Positioning

Crimping Plug

Place the plug into a suitable crimp tool with hexagonal crimp of 4.85 mm across flats. Use crimp tool to fasten the cable onto the plug. Ensure the crimp ring is tight and the duplex latching plug is undamaged after crimping.



FIGURE 5. Secure Duplex Connector

Polishing

Insert the connector fully into a polishing disc. Press the disc on polishing paper (600 grit) and polish the fiber until it is flush with the connector. Rotate in a figure of 8 format which will erode the core material of the cable. Use a hard and plain support plate (e.g. glass plate).

After polishing, wipe the connector with a clean tissue removing foreign particles. Using 3 μm grit, polish again for a smooth surface and wipe clean again. Best attenuation values are achieved applying wet polishing.



FIGURE 6. Polishing Disc

For the most recent revision or further information please visit www.firecomms.com or contact the company directly at the following address, Firecomms Ltd, 2200 Airport Business Park, Cork, IRELAND. Copyright© 2004-2023 Firecomms. All rights reserved. Firecomms refers to Firecomms Limited and/or its subsidiaries. Firecomms assumes no responsibility for inaccuracies or omissions in the information contained in this document. Specifications are subject to change without notice. No patent rights are granted to any of the circuits described herein.