

FB2M5KVR

250 Mbps Fiber Optic OptoLock® Transceiver

Data Sheet



DESCRIPTION

Firecomms Industrial OptoLock® transceiver has a small form factor housing which combines a pair of Firecomms fiber optic components to provide instant termination for bare Plastic Optical Fiber (POF). This POF port significantly simplifies the optical connection and as a consequence reduces time spent in maintenance of industrial equipment.

This version of OptoLock® carries a pair of Fiber Optic Transceivers (FOTs) designed to provide fast data links over POF in industrial environments. The FOTs are compatible with low-voltage differential signalling (LVDS) for seamless integration into existing logic bus structures and are ideal for use with an FPGA or ASIC.

The transceiver has electrical power saving features. In the transmitter, the driver IC goes into a sleep state and the RCLED is switched off if there is no data or pulse toning on the input bus. Similarly, if there is no optical signal present, the RX IC will switch into a sleep mode with RX power consumption reduced to a value of 25 µA or less. OptoLock® is protected by U.S. patents 7,597,485 and 7,905,665, Chinese patents 101501545 A and 102135650 B and other international patents.

AVAILABLE OPTIONS

Industrial OptoLock® Transceiver, 2.2 mm POF, Black	FB2M5KVR
--	-----------------



FEATURES

- Simple low-cost termination solution for 2.2 mm jacketed POF cables without a plug
- Compatible with 8B/10B encoding schemes: 250 Mbps is the NRZ symbol rate
- Resonant Cavity LED (RCLED) at red 650 nm with small emission aperture suitable for POF
- Integrated CMOS driver IC for RCLED
- High sensitivity CMOS receiver IC and PIN diode for one-step light to digital conversion
- Integrated optics to efficiently focus and direct light
- Low power consumption with power saving features
- -20 °C to +85 °C operating range
- RoHS compliant

APPLICATIONS

Application	Industrial and Robotic Links
Standard	LVDS Bus
Distance	50 meters Step Index POF ^[1]
Speed	250 Mbps

Note: 1. Depending on the installation conditions

SPECIFICATIONS

Table 3
TRANSCIVER PIN DESCRIPTION

Pin	Name	Symbol
Transmitter		
1	EMI Shield ^[1]	GND
2	Signal Input (Negative)	TD-
3	Signal Input (Positive)	TD+
4	Ground Pin ^[1]	GND
5	DC Power Input Pin 3.3 V	Vcc
6	Ground Pin ^[1]	GND
Receiver		
7	DC Power Input Pin 3.3 V	Vcc
8	Ground Pin ^[1]	GND
9	Signal Detect Output	SD
10	Data Output (Negative)	RD-
11	Data Output (Positive)	RD+
12	EMI Shield ^[1]	GND

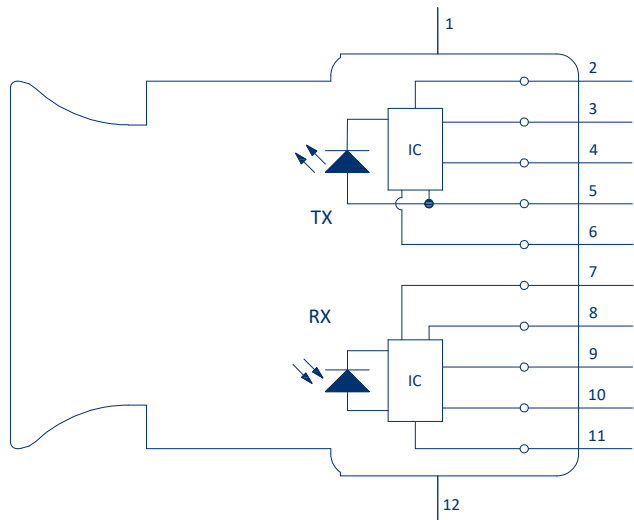

FIGURE 1
Transceiver pin-out, top view

1. NB: EMI Shield ground pins must be connected to the signal ground plane on the PCB. This is important to prevent cross-talk between TX and RX and also to shield the FOT's from external EMI/EMC and ESD

Table 4
REGULATORY COMPLIANCE

Parameter	Symbol	Standard	Level
Storage Compliance	MSL	J-STD-020E	2a (4-week floor life)
Restriction of Hazardous Substances Directive	RoHS	Directive 2011/65/EU	Certified compliant
Eye Safety		IEC 60825-1	LED Class 1

RECOMMENDED APPLICATION CIRCUIT

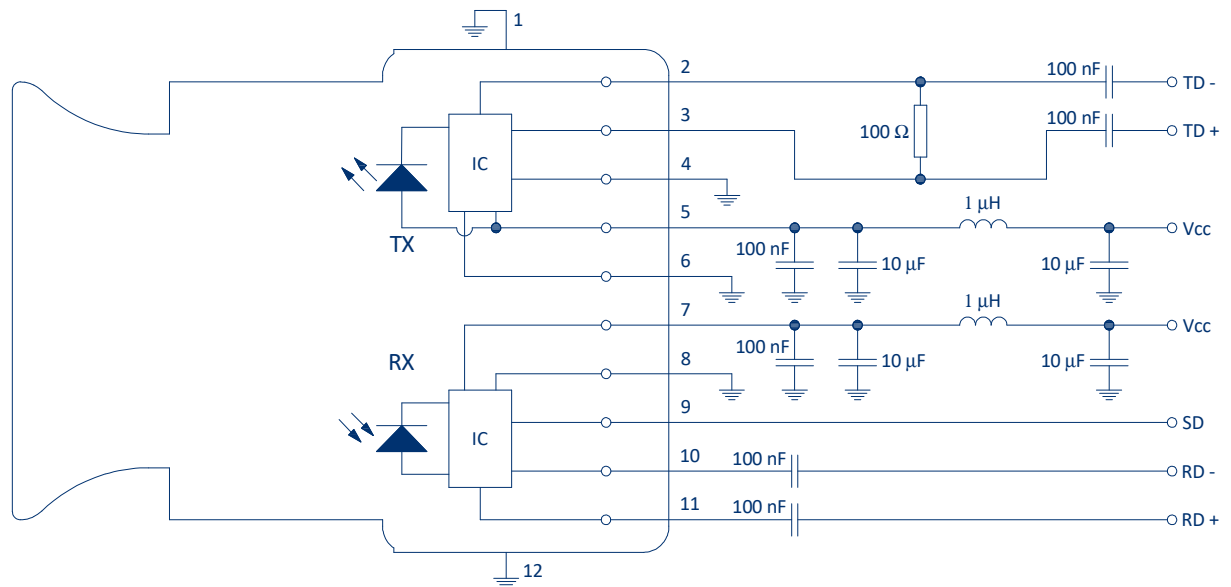

FIGURE 2
Recommended application circuit schematic to AC couple to a PHY

Notes:

1. The transmitter (TX) and receiver (RX) are electrically shielded from each other to prevent crosstalk. To be effective this shield must be grounded
2. Both GND pins of the TX FOT must be connected to GND (they are not connected internally).
3. Power line capacitors should be located as close as possible to the FOT's DC power PINS.
4. The data lines are impedance-matched differential pairs. The PCB layout for these tracks must comply to IEEE standards for high-speed data and impedance matching.
5. Note: The RD + and RD – are already terminated with a 100 Ω resistor internally at the output stage.

ELECTRONIC BLOCK DIAGRAM

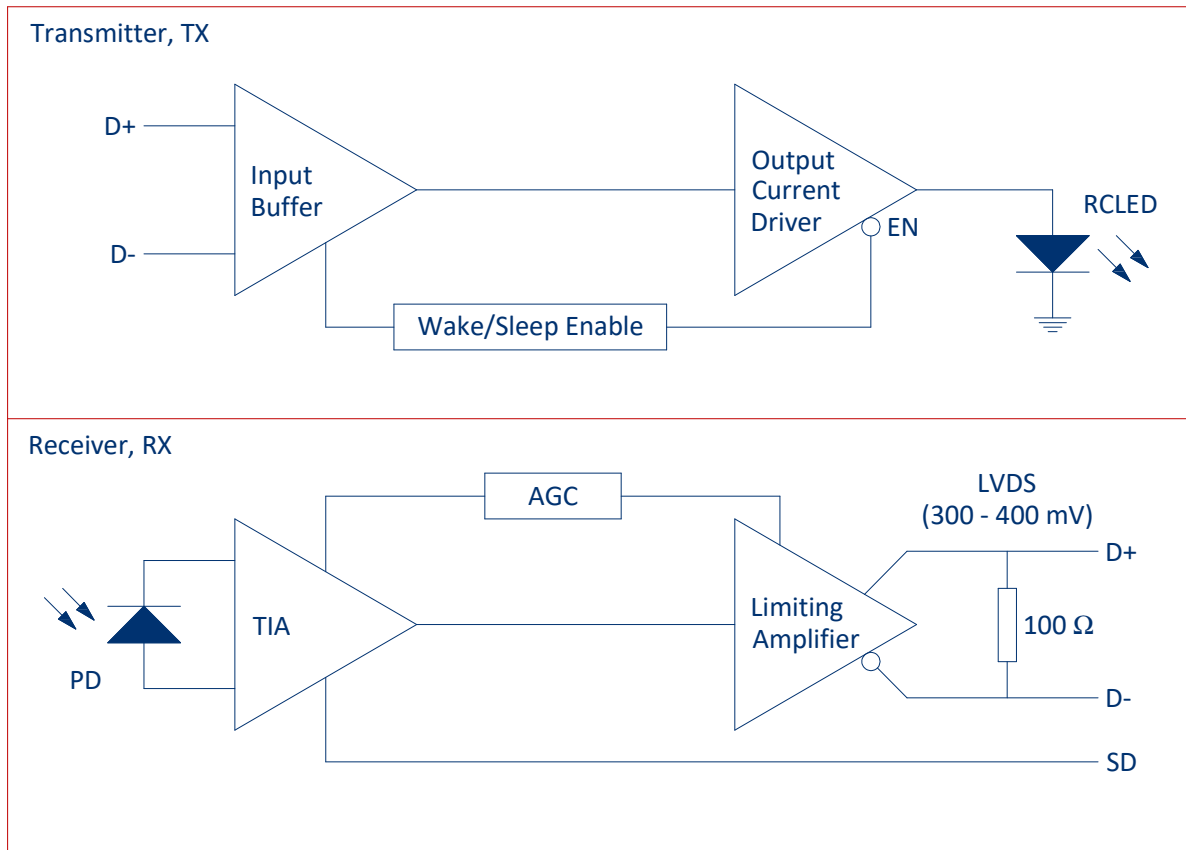

FIGURE 3
Electronic block diagrams of the TX and RX fiber optic transceivers

SPECIFICATIONS

Table 5
ABSOLUTE MAXIMUM RATINGS

Parameter	Symbol	Minimum	Maximum	Unit
Storage Temperature	T_{stg}	-40	+85	°C
Operating Temperature	T_{op}	-20	+85	°C
Soldering Temperature ^[1]	T_{slid}		+260 ^[1]	°C
Supply Voltage	V_R	-0.5	4.5	V
Receiver Optical Overload	P_{OL}		0	dBm

SPECIFICATIONS

Table 6
TRANSMITTER ELECTRICAL AND OPTICAL CHARACTERISTICS

Parameter	Symbol	Min	Typical	Max	Unit	Test Condition
DC Supply Voltage	V _{CC}	3.0	3.3	3.6	V	
Operating Current Consumption	I _{CC}		37	52	mA	
Sleep State Current Consumption	I _{Sleep}		20	40	μA	< 30 dBm of Light
Data Rate	Baud Rate	10		250	Mbps	
Data Input Capacitance	C _{IN}			5	pF	
Data Input Resistance (Single-Ended)	R _{IN}		5		kΩ	
Input Common-Mode Range	V _{IN-BIAS}	GND+0.8		V _{CC} -0.8	V	
Input Voltage Swing	V _{IN-SWING}	100		1200	mV	
Minimum Differential Voltage Swing to Ensure Wake-Up	Wake-up Input	50			mV	
Wake-Up Time Delay			5	80	μs	
Optical Power OFF Delay		0.02		20	μs	
Peak Wavelength	λ _{peak}	640	660	670	nm	
Spectral Bandwidth (FWHM)	Δλ		23	30	nm	
Average Optical Power	P	-10		-2.0	dBm	[3]
Rise Time (20 % - 80 %)	t _R		2.0	2.8	ns	
Optical Fall Time (20 % - 80 %)	t _F	0.3		0.6	ns	
Optical Modulation Amplitude	OMA	160	590	1250	μW	
Total Jitter				1.6	ns	

Table 7
RECEIVER ELECTRICAL AND OPTICAL CHARACTERISTICS

Test Conditions:

1. Test data was validated over the full temperature range of -20 °C to +85 °C, and over the supply range of 3 V to 3.6 V
2. Test data represents operation at the maximum data rate of 200 Mbps using a PRBS7 test pattern (8B/10B encoding, 250 MBd) unless otherwise stated
3. Optical power was coupled from a minimum 0.5 m length of 1 mm diameter core and 0.5 NA step index POF

Parameter	Symbol	Min	Typical	Max	Unit	Test Condition
DC Supply Voltage	V _{cc}	3.0	3.3	3.6	V	
Operating Current Consumption	I _{cc}	34	36	40	mA	
Sleep State Current Consumption	I _{sleep}	2	20	25	μA	
Output Impedance Between D and D			100		Ohm	
Offset Common Mode Voltage	V _{ocm}		1.2		V	
Output Differential Voltage Swing		300	350	400	mV	
Receivable Optical Power Sensitivity			-24	-22	dBm	
Maximum Allowed Optical Power				0	dBm	
Rise Time (10 % - 90 %)			1.0	2.5	ns	
Fall Time (90 % - 10 %)			1.0	2.0	ns	
Wake Up Time from Sleep State			10	100	μs	

MECHANICAL DATA

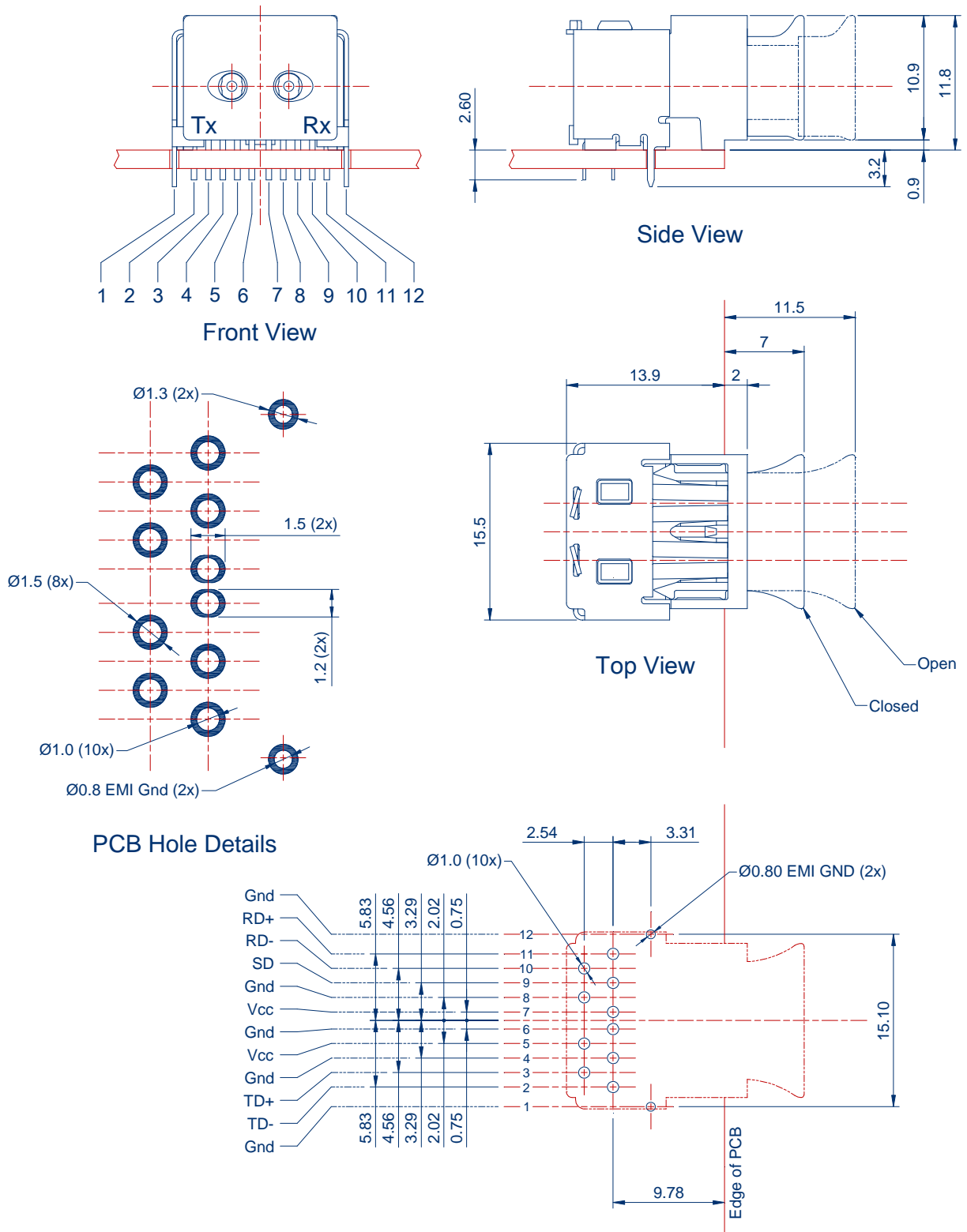

FIGURE 4

Mechanical dimensions of the product, and PCB footprint, which is a top view

General dimensional tolerance is ± 0.2 mm.

NOTE: For PCB layout extra care is required with pin 6 and pin 7. On the PCB top and bottom metal they require a non-circular pad. The VIA's are standard plated circular through holes, however, the VIA top and bottom solder pad areas are non-circular 1.2 mm wide and 1.5 mm long oval shapes.

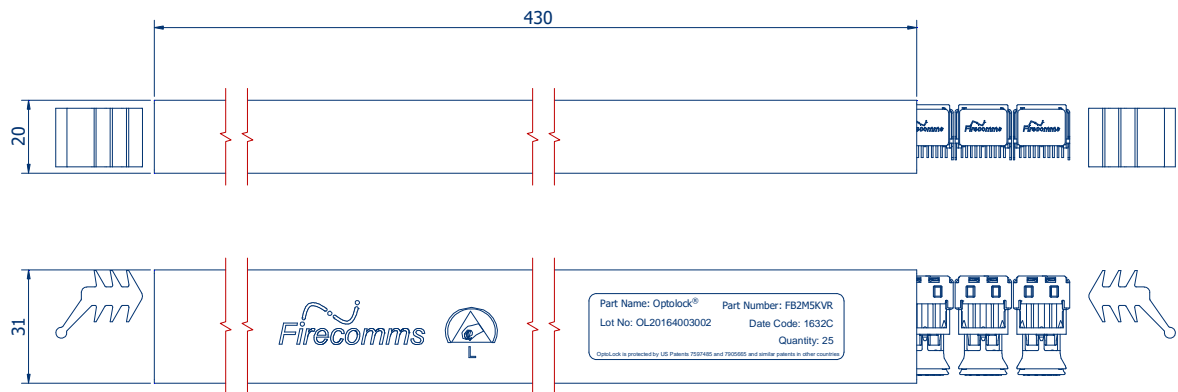

FIGURE 5
Packing tube for Firecomms FB2M5KVR OptoLock® Transceivers

PART HANDLING

The transceivers are tested for handling in static-controlled assembly processes (HBM). Cleaning, degreasing and post solder washing should be carried out using standard solutions compatible with both plastics and the environment. For example, recommended solutions for degreasing are alcohols (methyl, isopropyl and isobutyl). Acetone, ethyl acetate, phenol or similar solution based products are not permitted.

In the soldering process, non-halogenated water soluble fluxes are recommended. These components are not suitable for use in reflow solder processes (infrared/vapor-phase reflow). The dust plug should remain in place during soldering, washing and drying processes to avoid contamination of the active optical area of each connector.

The Moisture Sensitivity Level (MSL) classification of this device is 2a according to JEDEC J-STD-020E. The shelf life of an unopened MBB (Moisture Barrier Bag) is 24 months at < 40 °C and < 90 % R.H. Once the Moisture Barrier Bag is opened the devices can be either

- a) Stored in normal factory conditions < 30 °C and < 60 % R.H. for a maximum of 672 hours (4 Weeks) prior to soldering.
- b) Stored at < 10 % R.H. (Dry Cabinet).

PACKING INFORMATION

Components are packed in PVC anti-static tubes in moisture barrier bags. Bags should be opened only in static-controlled locations, and standard procedures should be followed for handling moisture sensitive components

Components per Tube	25
Tube Length	430 mm
Tube Width	31 mm
Tube Height	20 mm
Tubes per Bag	10
Bags per Inner Carton	1
Inner Carton Length	588 mm
Inner Carton Width	147 mm
Inner Carton Height	84 mm
Weight per Inner Carton, Complete	1.80 kg
Components per Inner Carton	250
Inner Cartons per Outer Carton	4
Outer Carton Length	600 mm
Outer Carton Width	310 mm
Outer Carton Height	195 mm
Weight per Outer Carton, Complete	7.53 kg
Components per Outer Carton	1000

For the most recent revision or further information please visit www.firecomms.com or contact the company directly at the following address, Firecomms Ltd, 2200 Airport Business Park, Cork, IRELAND. Copyright© 2004-2017 Firecomms. All rights reserved. Firecomms refers to Firecomms Limited and/or its subsidiaries. Firecomms assumes no responsibility for inaccuracies or omissions in the information contained in this document. Specifications are subject to change without notice. No patent rights are granted to any of the circuits described herein.