

OBSOLETE

* For new designs please see part number: FT01MHNR

FT01MxNG

530 nm DC-1 MBd RedLink®

Fiber Optic Transmitter

Datasheet



DESCRIPTION

Firecomms DC to 1 MBd green 530 nm transmitter is designed for maximum distance at low-speed communication in Plastic Optic Fiber (POF). It is housed in a non-conducting plastic RedLink® connector. The housings are compatible with the Versatile Link style fiber plug and are optimised for use with both POF and Polymer Clad Silica (PCS).

The transmitter can be driven from TTL type logic drivers. It operates over the industrial temperature range of -40 °C to +85 °C, supporting many industrial applications where reliable command and control response is required in electrically harsh environments.

The transmitter utilizes an eye-safe, highly-efficient gallium nitride LED. Since the attenuation of POF is lower at green wavelengths a maximum link distance of greater than 150 m can be easily achieved. The transmitter operates over a wide range of drive current that can be adjusted using a serial resistor to minimise current consumption for known fiber distances.

FEATURES

- Optimised for data rates from DC to 1 MBd
- Visible LED at green wavelength (530 nm)
- Extended length applications over POF (150 - 200 m, depending on data rate)
- Industrial temperature range -40 °C to +85 °C
- RoHS compliant and flame retardant (UL 94 V-0) connector housings
- TTL/CMOS compatible for ease of design
- Low pulse width distortion
- Low current consumption
- Compatible with Versatile Link cables and connectors

AVAILABLE OPTIONS

Table 1

ORDERING INFORMATION / PART NUMBERS

1 MBd Horizontal Package Non-Inverting, TTL	FT01MHNG
1 MBd Vertical Package Non-Inverting, TTL	FT01MVNG
1 MBd Tilted Package Non- Inverting, TTL	FT01MWNG

APPLICATIONS

Table 2
APPLICATIONS

Application	Motor Control, Voltage Isolation, Drives, Inverters, Industrial Control, Gaming, Medical Imaging
Standard	Low-speed serial RS232, RS485, CAN Bus, Modbus, PROFIBUS
Distance	150 – 200 meters Step Index (SI) POF depending upon ambient temperature and installation conditions
Speed	DC to 1 MBd

SPECIFICATIONS

Table 3
TRANSMITTER PIN DESCRIPTION

Pin	Name	Symbol
1	LED ANODE	TD+
2	LED CATHODE	TD-
3	LED ANODE	TD+
4	LED ANODE	TD+
5	RETAINING PIN	GND
8	RETAINING PIN	GND

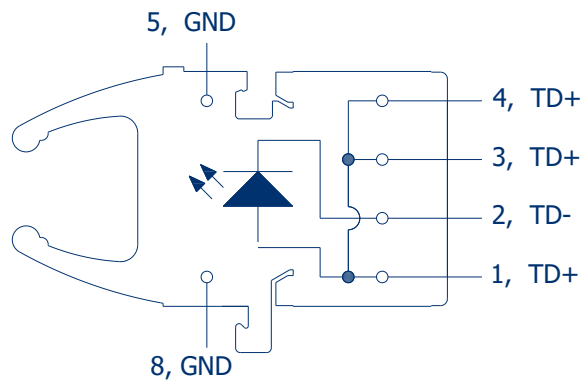

FIGURE 1
Transmitter pin-out, top view

Table 4
REGULATORY COMPLIANCE

Parameter	Symbol	Standard	Level
Electrostatic Discharge, Human Body Model (contact ESD)	HBM	Mil-STD-883	Level 2 (4 kV)
Radiated Emissions Immunity	Vm^{-1}	IEC 61000-4-3	15 Vm^{-1}
UL Certification	UL	60950-1	File No. E362227
Storage Compliance	MSL	J-STD-020	2a (4-week floor life)
Restriction of Hazardous Substances Directive	RoHS	Directive 2011/65/EU Incl. Amendment 2015/863	Certified compliant
Eye Safety		IEC 60825-1	LED Class 1

RECOMMENDED APPLICATION CIRCUIT

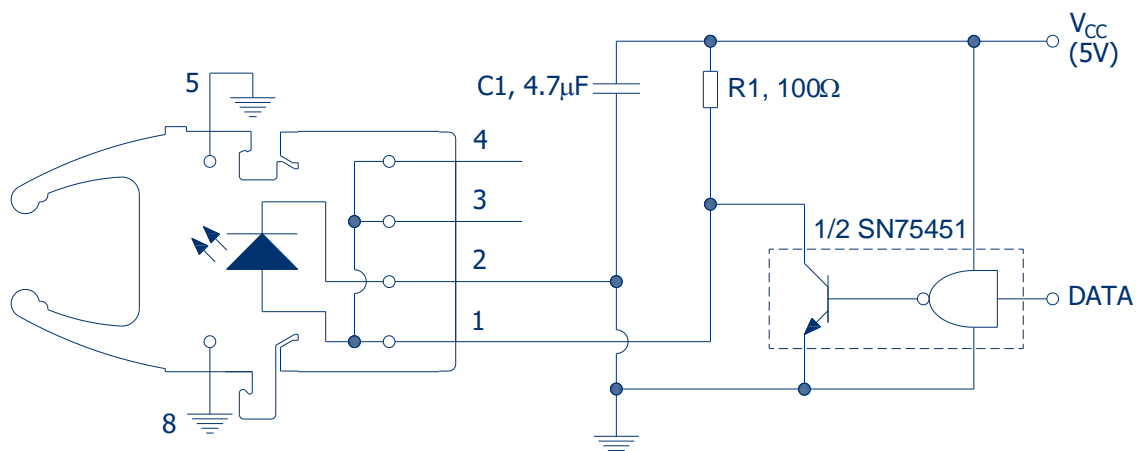

FIGURE 2
Recommended transmitter application circuit. See note 4, Table 6

SPECIFICATIONS

Table 5
ABSOLUTE MAXIMUM RATINGS

These are the absolute maximum ratings at or beyond which the component can be expected to be damaged.

Notes:

1. 260 °C for 10 sec, one time only, at least 2.2 mm away from lead root
2. When peak forward current exceeds 20 mA then the duty cycle must maintain a pulse width (PW) less than 1 μ s and average forward current less than or equal to 20 mA. [$20 \text{ mA} \leq I_{\text{FPK}} \leq 40 \text{ mA} \leftrightarrow I_{\text{FAVG}} \leq 20 \text{ mA AND PW} \leq 1 \mu\text{s}$]

Parameter	Symbol	Minimum	Maximum	Unit
Storage Temperature	T_{stg}	-40	+85	°C
Operating Temperature	T_{op}	-40	+85	°C
Soldering Temperature ^[1]	T_{sld}		+260 [1]	°C
Tx Reverse Input Voltage	V_{BR}		5	V
Tx Peak Forward Input Current ^[2]	I_{FPK}		40	mA
Tx Average Forward Input Current ^[2]	I_{FAVG}		20	mA

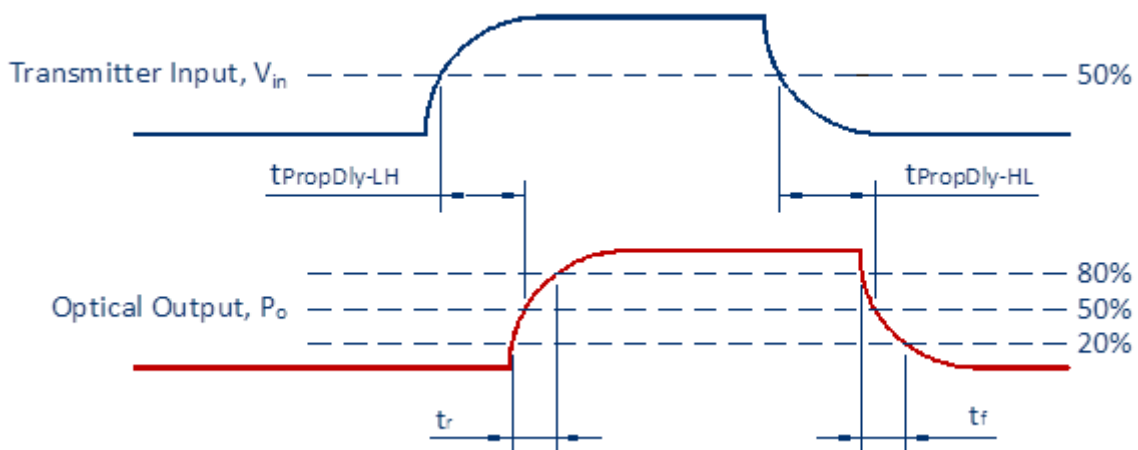

FIGURE 3
Transmitter propagation delay and rise/fall time definitions as per application circuit of Figure 2

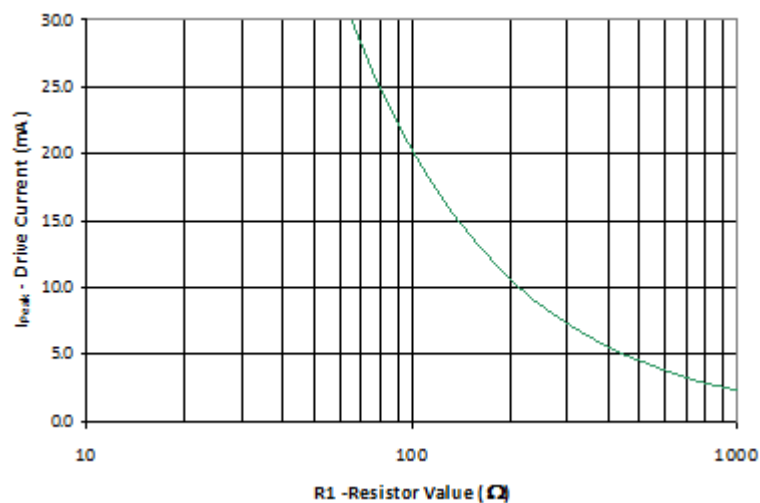

FIGURE 4
Graph of peak drive current against series resistance (R_1)

SPECIFICATIONS

Table 6
TRANSMITTER ELECTRICAL AND OPTICAL CHARACTERISTICS

Parameter	Symbol	Min	Typical	Max	Unit	Test Condition
<i>Test Conditions:</i>						
1. Test data was validated over the full temperature range of -40°C to +85°C, and over the full drive current range						
2. Optical power for POF is measured when coupled into 0.5 m of a 1 mm diameter 0.5 NA POF and a large area detector						
3. As measured in the given application circuit (non-inverting) as shown in Figure 2 with 50 cm of 0.5 NA POF						
4. Pins 5 and 8 are only used for mounting and retention purposes. Connect to ground.						
Output Power	P	-2	1	4	dBm	I _{FDC} = 20 mA
Peak Emission	λ_p	520	530	540	nm	I _{FDC} = 20 mA
Spectral Width	RMS	15	20	30	nm	I _{FDC} = 20 mA
Forward Voltage	V _F	2.5	3.0	3.5	V	I _{FDC} = 20 mA
Reverse Input Breakdown Voltage	V _{BR}	10			V	I _{FDC} = -10 μ A
Data Rate		DC		1	MBd	
Optical Rise Time (20 % - 80 %)	t _r		50	90	ns	I _{FAVG} = 10 mA ^[3]
Optical Fall Time (80 % - 20 %)	t _f		40	100	ns	I _{FAVG} = 10 mA ^[3]
Propagation Delay Low-to-High (Electrical-to-Optical)	PropDly _{LH}	49	67	96	ns	I _{FAVG} = 10 mA ^[3] , Fig 3
Propagation Delay High-to-Low (Electrical-to-Optical)	PropDly _{HL}	27	34	53	ns	I _{FAVG} = 10 mA ^[3] , Fig 3
Pulse Width Distortion	PWD	-18	-34	-52	ns	I _{FAVG} = 10 mA ^[3] , Fig 3

SPECIFICATIONS

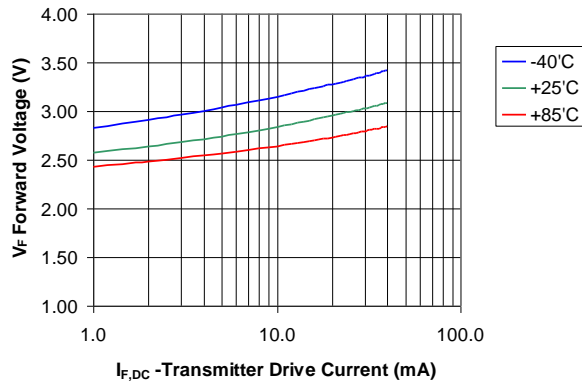

FIGURE 5
Typical forward voltage vs. drive current

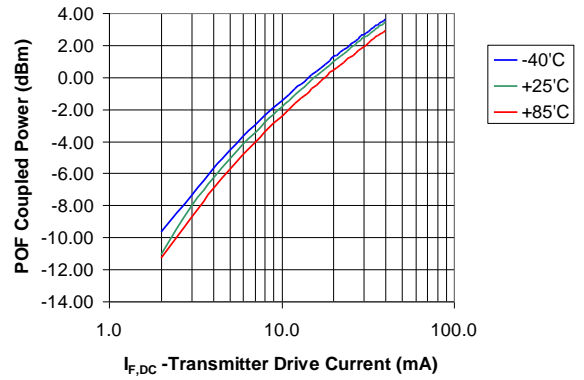

FIGURE 6
Typical optical output power vs. drive current

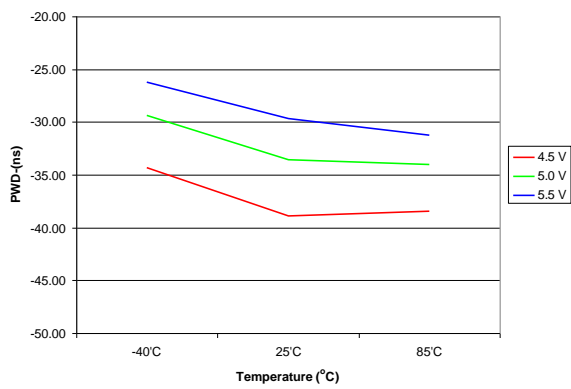

FIGURE 7
Typical pulse width distortion vs. temperature

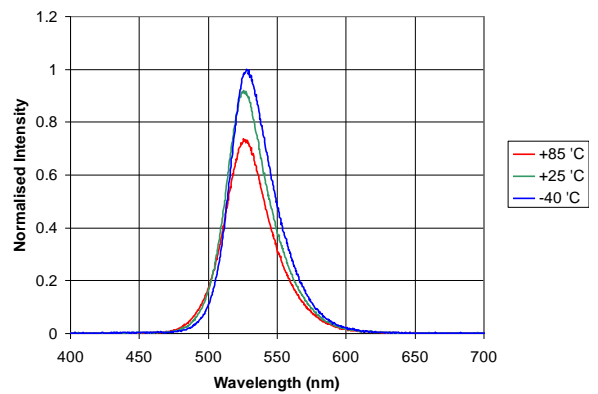

FIGURE 8
Typical spectra vs. temperature

MECHANICAL DATA, HORIZONTAL

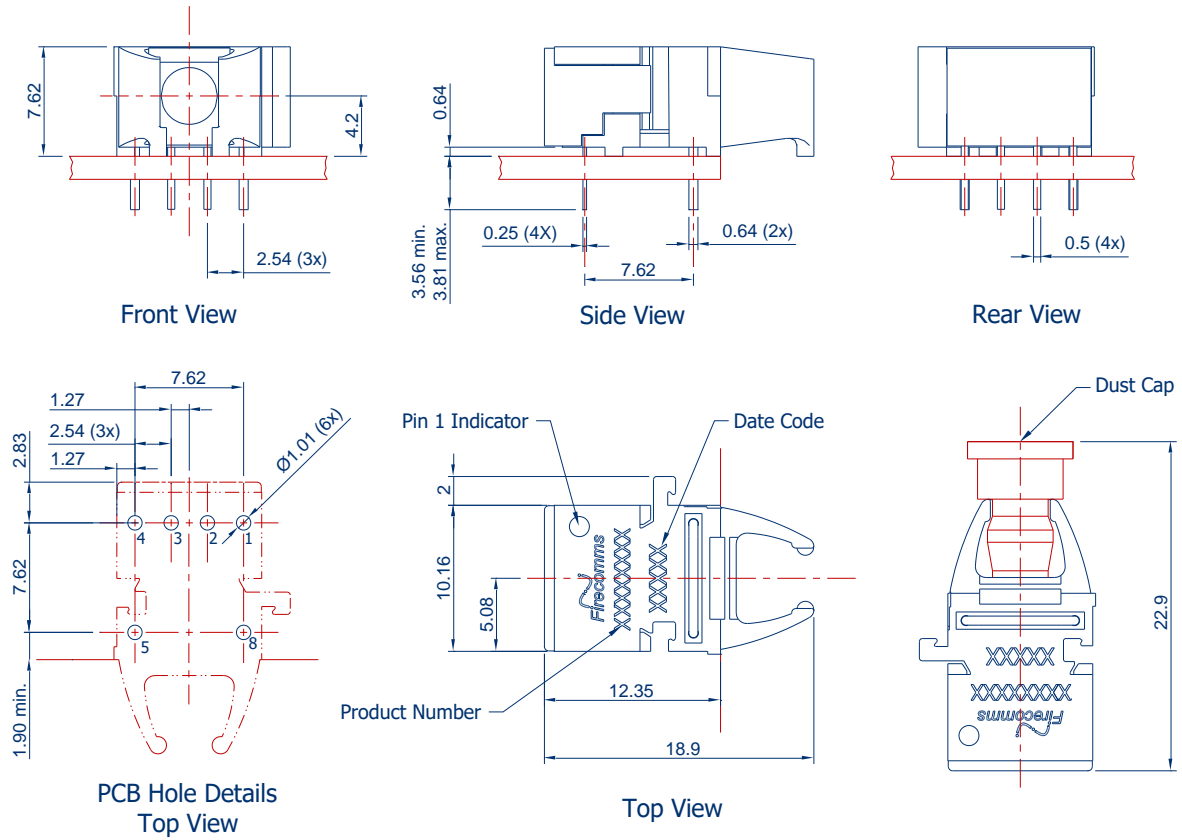

FIGURE 8
Mechanical dimensions of RedLink® horizontal connectors and PCB footprint, which is a top view
 General dimensional tolerance is ± 0.2 mm

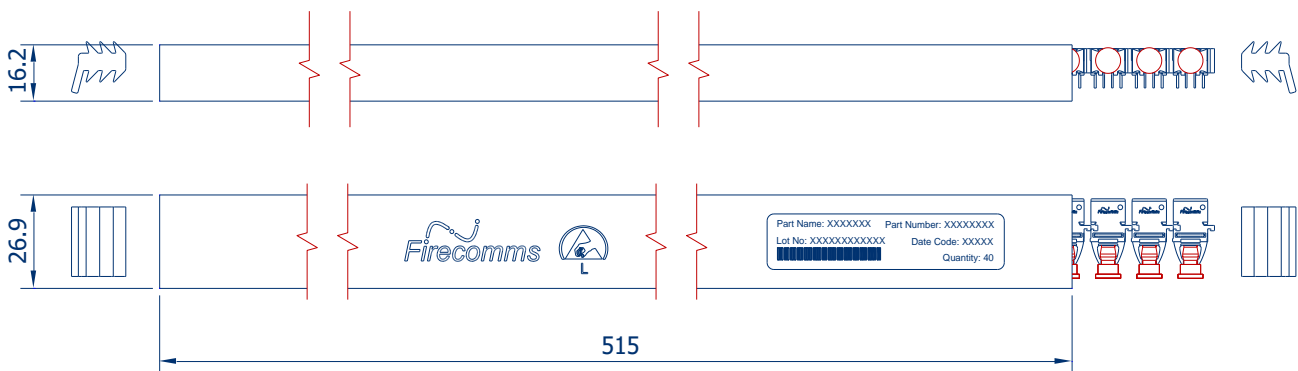

FIGURE 9
Packing tube for Firecomms RedLink® horizontal connectors

MECHANICAL DATA, VERTICAL

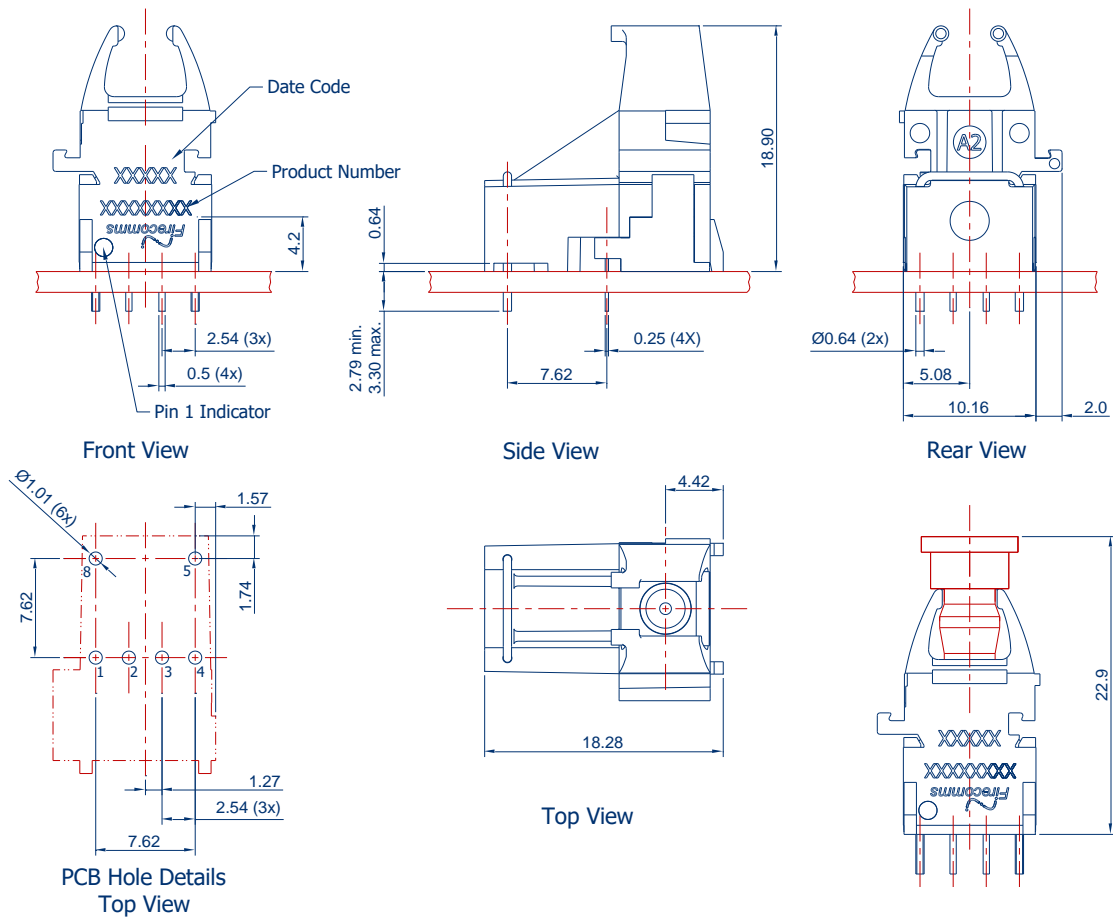

FIGURE 10
 Mechanical dimensions of RedLink® vertical connectors and PCB footprint, which is a top view
 General dimensional tolerance is ± 0.2 mm

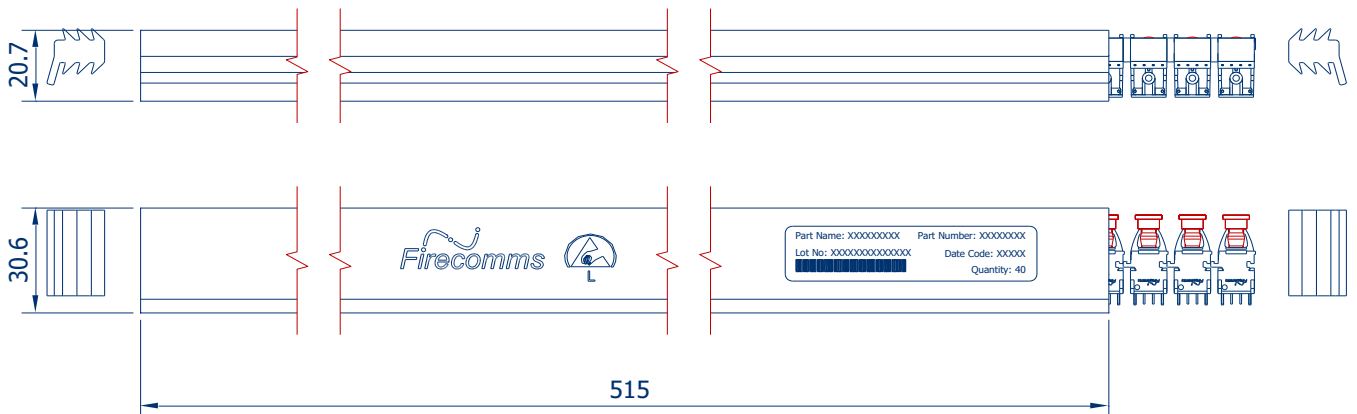

FIGURE 11
 Packing tube for Firecomms RedLink® vertical connectors

MECHANICAL DATA, 30° TILTED

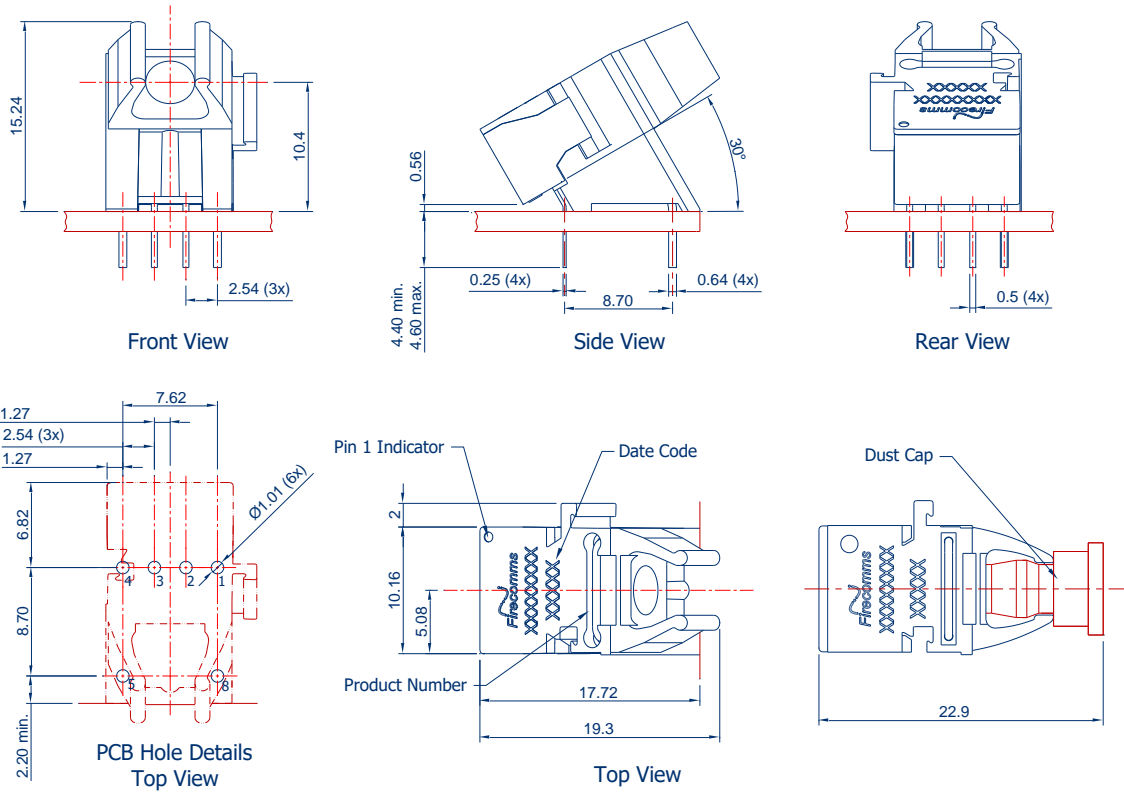

FIGURE 12
Mechanical dimensions of RedLink® tilted connectors and PCB footprint, which is a top view
General dimensional tolerance is ± 0.2 mm

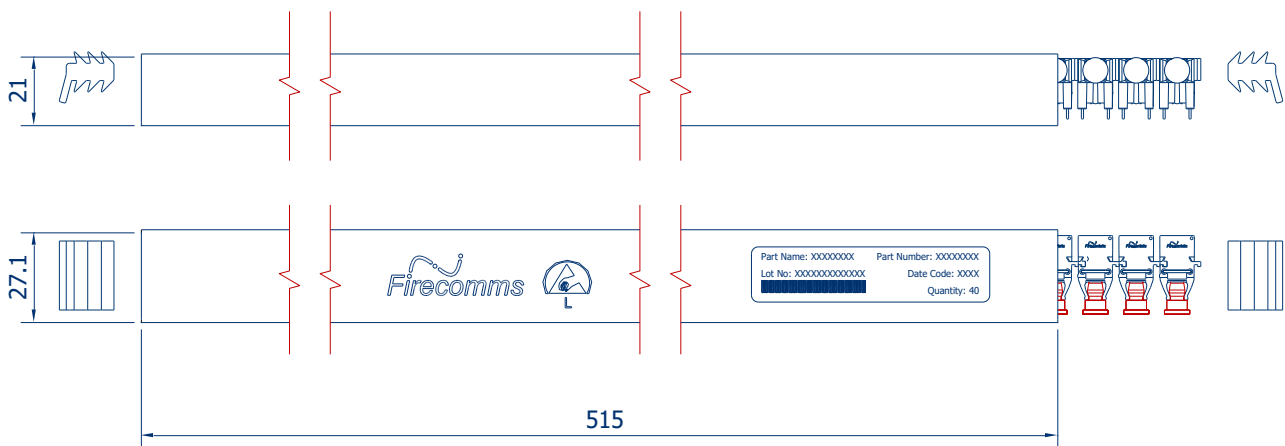

FIGURE 13
Packing tube for Firecomms RedLink® tilted connectors

PART HANDLING

Firecomms RedLink[®] connectors are auto-insertable and tested for handling in static-controlled assembly processes (Human Body Model - HBM). Cleaning, degreasing and post solder washing should be carried out using standard solutions compatible with both plastics and the environment. For example, recommended solutions for degreasing are alcohols (methyl, isopropyl and isobutyl). Acetone, ethyl acetate, phenol or similar solution-based products are not permitted.

In the soldering process, non-halogenated water-soluble fluxes are recommended. RedLink[®] connectors are not suitable for use in reflow solder processes (infrared/vapor-phase reflow). The dust plug should remain in place during soldering, washing and drying processes to avoid contamination of the active optical area of each part.

The Moisture Sensitivity Level (MSL) classification of this device is 2a according to JEDEC J-STD-020.

The shelf life of an unopened MBB (Moisture Barrier Bag) is 24 months at < 40 °C and < 90 % R.H.

Once the Moisture Barrier Bag is opened, the devices can be either;

- a) Stored in normal factory conditions < 30 °C and < 60 % R.H. for a maximum of 672 hours (4 Weeks) prior to soldering
- b) Stored at < 10 % R.H. (Dry Cabinet)

PACKING INFORMATION

Components are packed in PVC anti-static tubes and in moisture barrier bags. Bags should be opened only in static-controlled locations, and standard procedures should be followed for handling moisture sensitive components.

Table 7
PACKING INFORMATION

	Horizontal	Vertical	Tilted
Components per Tube	40	40	40
Tube Length	515 mm	515 mm	515 mm
Tube Height	16.2 mm	20.7 mm	21 mm
Tube Depth	26.9 mm	30.6 mm	27.1 mm
Tubes per Bag	5	5	5
Bags per Inner Carton	1	1	1
Inner Carton Length	630 mm	630 mm	630 mm
Inner Carton Width	70 mm	70 mm	70 mm
Inner Carton Height	105 mm	105 mm	105 mm
Weight per Inner Carton, Complete	0.77 kg	0.92 kg	0.92 kg
Components per Inner Carton	200	200	200
Inner Cartons per Outer Carton	10	10	10
Outer Carton Length	650 mm	650 mm	650 mm
Outer Carton Width	235 mm	235 mm	235 mm
Outer Carton Height	376 mm	376 mm	376 mm
Weight per Outer Carton, Complete	8.13 kg	9.60 kg	9.60 kg
Components per Outer Carton	2,000	2,000	2,000

For the most recent revision or further information please visit www.firecomms.com or contact the company directly at the following address, Firecomms Ltd, 2200 Airport Business Park, Cork, IRELAND. Copyright© 2004-2022 Firecomms. All rights reserved. Firecomms refers to Firecomms Limited and/or its subsidiaries. Firecomms assumes no responsibility for inaccuracies or omissions in the information contained in this document. Specifications are subject to change without notice. No patent rights are granted to any of the circuits described herein.